

Design Documents for Products by AMiT

Abstract

Basic Design Concepts of Control Systems by AMiT.

Author: Zbyněk Říha
File: ap0050_en_01.pdf

Appendix

File content: –

–	None

Contents

	Revision history	4
	Related documents	4
1	Introduction	6
2	Power Supply	7
2.1	Source dimensions.....	7
2.1.1	Source dimensions calculation	7
2.2	Cabling.....	8
2.3	Overvoltage protection	9
3	Communication	11
3.1	RS232.....	11
3.1.1	Connecting a PC to the control system.....	11
3.1.2	Connecting a serial terminal to the control system	12
3.1.3	Connecting a modem to the control system.....	12
3.1.4	Connecting a communication converter to the control system	14
3.2	RS485.....	14
3.3	CAN	15
3.4	M-Bus.....	15
3.5	Interface for a Parallel Terminal.....	16
3.6	Ethernet	16
3.7	OpenTherm.....	17
3.8	MP-Bus	17
3.9	Connecting Other Communication Interfaces	17
4	Digital Inputs	18
4.1	Digital inputs parameters.....	18
4.2	Connecting an active signal.....	18
4.3	Connecting a passive contact.....	19
4.4	Connecting a dry contact.....	19
4.5	Connecting IRC sensors	20
4.6	Cabling.....	20
4.7	Overvoltage protection	21
5	Digital Outputs	22
5.1	Digital outputs parameters.....	22
5.2	Connecting digital active elements	22
5.2.1	Connecting relays, contactors	22
5.2.2	Connecting an actuator (three-position control)	23
5.3	Cabling.....	24
5.4	Suppressing Interference in Induction Elements.....	24
5.4.1	Suppressing interference using a varistor.....	24
5.4.2	Suppressing interference using an RC member	24
5.4.3	Suppressing interference using a diode.....	24
5.5	Overvoltage protection	25
6	Analogue Inputs	26
6.1	Analogue inputs parameters.....	26
6.2	Connecting Analogue Detectors and Sensors	26
6.2.1	Connecting Passive Sensors.....	26
6.2.2	Connecting a current sensor	26
6.2.3	Connecting a voltage sensor	27
6.2.4	Alternative Uses of Analogue Inputs.....	27

6.3	Cabling.....	28
6.4	Overvoltage protection	29
7	Analogue Outputs	30
7.1	Analogue output parameters	30
7.2	Connecting analogue active elements	30
7.3	Cabling.....	30
7.4	Overvoltage protection	30
8	Connecting ground terminals.....	32
8.1	Control system external circuits separated galvanically	32
8.2	Control system external circuits connected galvanically	33
9	Extending Control Systems with Further I/O.....	34
10	Technical Support.....	35
11	Warning.....	36

Revision history

Version	Date	Changes
001	27. 02. 2013	New document.

Related documents

1. Application note AP0002 – Communication in MP-Bus network
File: ap0002_en_xx.pdf
2. Application note AP0004 – Communication in GSM/GPRS network
File: ap0004_en_xx.pdf
3. Application note AP0007 – Communication in DIOCAN network
File: ap0007_en_xx.pdf
4. Application note AP0008 – Communication in MODBUS network
File: ap0008_en_xx.pdf
5. Application note AP0010 – Communication in M-BUS network
File: ap0010_en_xx.pdf
6. Application note AP0015 – Measuring temperature and resistance
File: ap0015_en_xx.pdf
7. Application Note AP0016 – Operating guidelines RS485
File: ap0016_en_xx.pdf
8. Application Note AP0017 – Sensor inputs, measuring rotations and impulses
File: ap0017_en_xx.pdf
9. Application note AP0019 – Communication in LON network
File: ap0019_en_xx.pdf
10. Application Note AP0025 – Communication in ARION network – chart definition
File: ap0025_en_xx.pdf
11. Application Note AP0027 – Connecting control systems and peripheral devices
File: ap0027_en_xx.pdf
12. Application note AP0009 – Communication in DB-Net network
File: ap0009_en_xx.pdf
13. Application note AP0029 – CAN network – Terms of Use
File: ap0029_en_xx.pdf
14. Application Note AP0030 – User guidelines for converter DM-DI4MB2ET
File: ap0030_en_xx.pdf
15. Application Note AP0032 – Installing CS on the DIN bar into the switchboard door
File: ap0032_en_xx.pdf
16. Application Note AP0033 – Alternative use of analog inputs
File: ap0033_en_xx.pdf
17. Application note AP0037 – Ethernet network – Terms of Use
File: ap0037_en_xx.pdf
18. Application Note AP0039 – Communication with electricity meters according to the norm
CSN EN 62056-21
File: ap0039_en_xx.pdf
19. Application Note AP0043 – Flash switching between applications
File: ap0043_en_xx.pdf

20. Application Note AP0046 – Web Server Parametrization

File: ap0046_en_xx.pdf

21. Application note AP0049 – Communication in GENIbus network

File: ap0049_en_xx.pdf

22. Catalogue list of individual cables

File: kabel232xxx_d_en_xxx.pdf

1 Introduction

The application note is designed for anyone who designs control systems made by the company AMiT. It provides general information on connecting digital/analogue inputs and outputs and communication interfaces. Detailed information to be followed when designing AMiT products is available in Operation Instruction for the respective products.

2 Power Supply

All control systems are equipped with a switched-mode power supply that efficiently transforms the power supply to the supply necessary for control system functioning. Supply terminals, depending on the control system type, are either separated or are not separated galvanically from the inner circuits of the control system, and that is why the ground terminals of analogue circuits, RS232 and the power supply are connected. This information is included in the corresponding catalogue list.

Control systems are powered from the power supply 24 V ss. $\pm 20\%$, or directly from the transformer 230 V / 24 V (or 230 V / 18 V), the supply depends on the control system configuration, see the corresponding technical instructions.

Maximum power supply permitted in the supply terminals of all control system must not exceed 33 V for direct-current power supply or 30 V efficient for alternating-current power supply, see the corresponding technical instructions

2.1 Source dimensions

When selecting a source for a specific application, we need to calculate the total consumption of the control system including the display terminal, all sensors and active elements connected that are powered from the same source. We also need to add the consumption of all digital inputs and relays to the resulting consumption if they are powered from the same source as the control system.

In case of inputs and sensors, we need to consider the maximum consumption:

- ◆ digital input 0.01 A
- ◆ analogue input 4 mA to 20 mA 0.02 A

In case of analogue outputs, we need to consider the maximum consumption:

- ◆ analogue output 0 V to 10 V 0.01 A
- ◆ analogue output 0 mA to 20 mA 0.02 A

2.1.1 Source dimensions calculation

In order to calculate the source dimensions, we need to follow the following formula

$$\text{Consumption} = I_{RMax} + I_{TMax} + x \times 0,01 + y \times 0,02 + I_{SRe} [A]$$

where

I_{RMax} control system maximum consumption

I_{TMax} terminal maximum consumption

I_{SRe} Total of relay currents

x Number of digital inputs / analogue voltage outputs connected into the control system

y Number of current sensors / analogue current outputs connected into the control system

To power a control system, it is suitable to use a power source with maximum output current at least by 30% higher than the maximum consumption calculated; it is because of build-up currents of devices connected.

Suitable sources to power control systems are stabilized sources by AMiT. A stabilized source provides constant output voltage even if the main 230 V voltage varies.

We can also use a transformer with a rectifier and a filter for power supply. When using a transformer, we need to take into account the network fluctuation and the transformer power in order to prevent the voltage on the control system terminal from exceeding its maximum value

33 V DC and from dropping the minimum voltage below 16 V DC at network tolerance 230 V from -10 % to +15 %.

The same rules apply for alternating-current power supply.

2.2 Cabling

The lead cable to control system power supply must run separately from power conductors and from industrial interference sources. For power supply, all conductors (both solid and stranded) with cross-section 1.5 mm² to 2.5 mm² for one conductor are suitable.

The power supply to control systems needs to be protected with a ballast fuse. Protection is not necessary only in case the power supply is equipped with a blow-out fuse or electronic limitation of the maximum current.

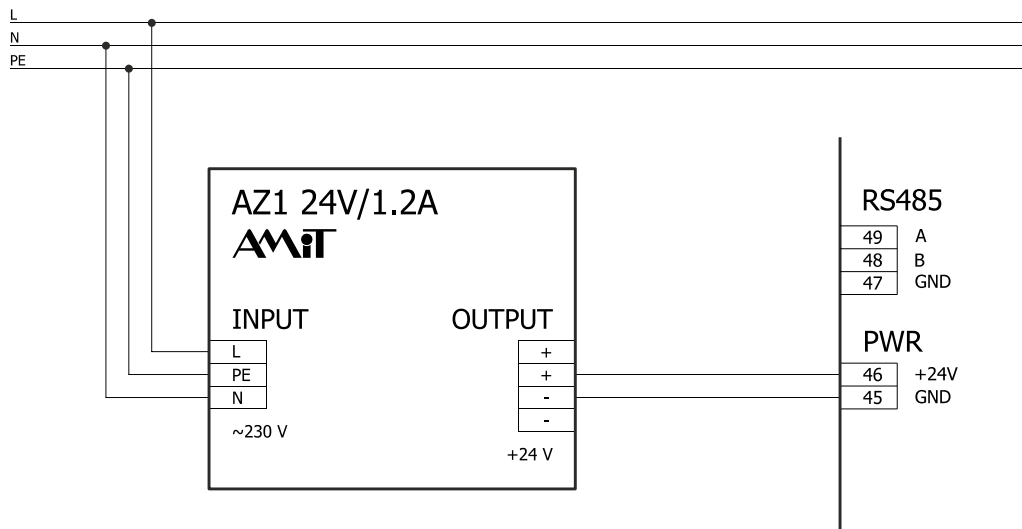

Fig. 1 – Using a source with integrated electronic protection

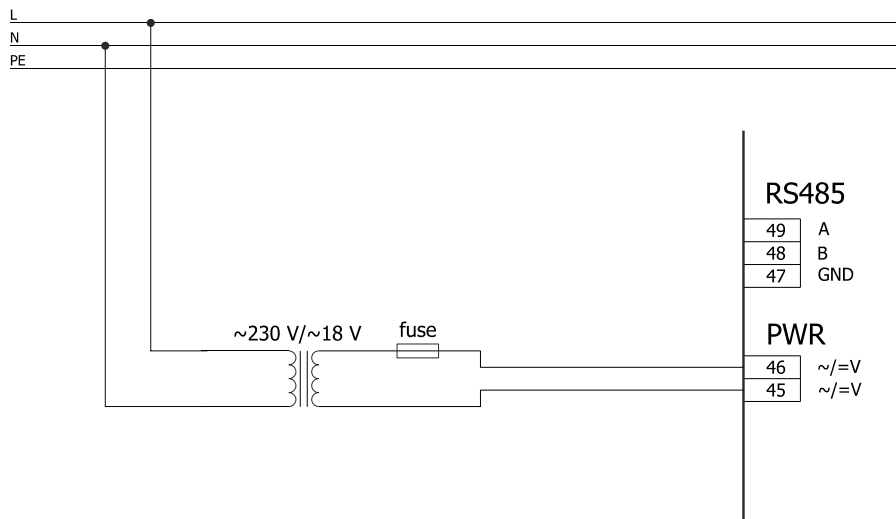

Fig. 2 – Using a source without integrated electronic protection (protected by a blow-out fuse)

2.3 Overvoltage protection

In order to increase the control system's endurance in terms of power supply, it is necessary to use overvoltage protection before plugging the device into power supply. When using a suitable type of protection, the control system is protected against pulse overvoltage and HF interference in the network. The issues of overvoltage protection use are covered in the standards EN 61 643-11 and IEC 664-1/CSN 330420-1. The text below on the use and connection of individual overvoltage protection levels is therefore to be considered as a set of orientation guidelines on the issue.

The protection is classified into three levels according to the level of overvoltage the protection is able to eliminate without destructive effects.

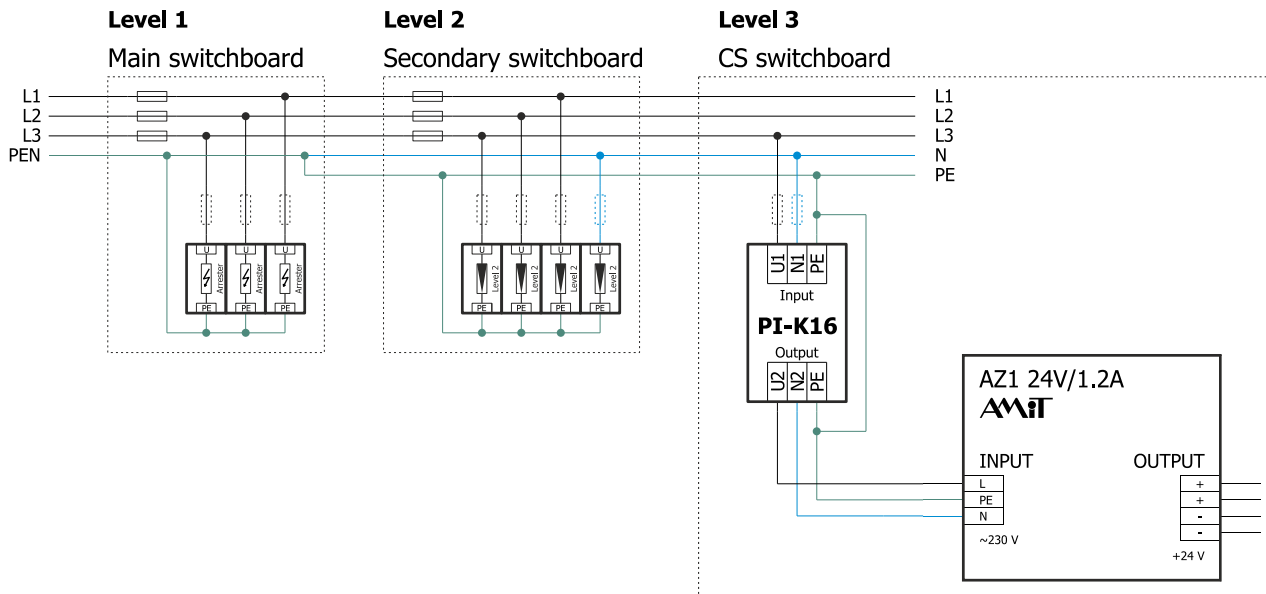

Fig. 3 – Connecting overvoltage protection in switchboards (TN-C network)

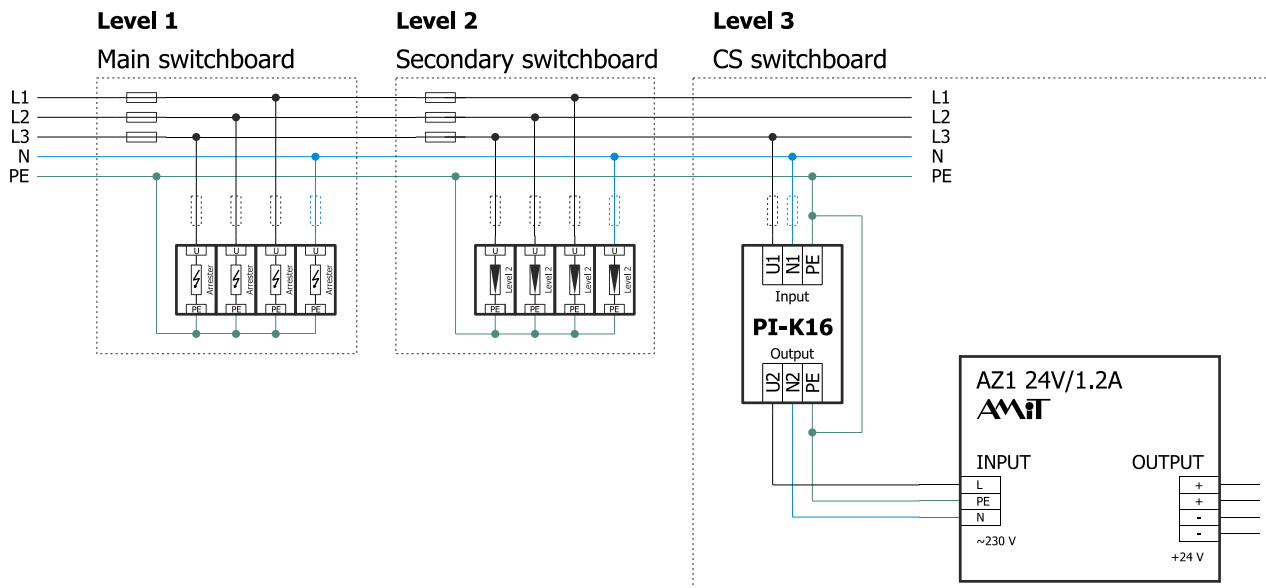

Fig. 4 – Connecting overvoltage protection in switchboards (TN-S network)

Level 1 Lightning Current Arrester

This protection level is placed into the object's primary switchboard. Level 1 protection is able to protect the device in the event of direct stroke of lightning.

Recommended types

- ◆ PIVM7-275 HAKEL spol. s r. o.
- ◆ FLP-B+C MAXI VS/3 SALTEK s.r.o.

Level 2 Overvoltage protection

This protection level is placed into the object's secondary switchboards. The protection is designed to limit the impact of medium voltage. This protection level does not sustain a direct stroke of lightning and the protection is destroyed upon the first discharge. Four single-phase protections can be used in a TN-S network. Types of protection available may differ according to the distance between level 1 and 2.

Recommended types

- ◆ PIII(M) 275 HAKEL spol. s r. o.
- ◆ SLP-275 V SALTEK s.r.o.

Level 3 Overvoltage protection

This protection level is placed into the object's secondary switchboards near the devices to be protected. The protection is designed to limit the impact of residual voltage and to follow up on the level 2 protections. This protection level does not sustain a direct stroke of lightning either. The protection is destroyed upon the first discharge; subsequent discharges go through unlimited and get to the device easily as it is no longer protected. These protections are often combined with a high frequency filter that limits the interference and radiation.

The distance between level 2 and level 3 must be at least 5 m, the distance between level 1 and 2 must be at least 10 m. If there is shorter distance between the protection levels, it is necessary to insert surge separating inductors between them (or to apply combined level 2 overvoltage protection). There can only be up to two subsequent levels in a single switchboard.

Recommended types

- ◆ PI-K16 protection with HF filter HAKEL spol. s r. o.
- ◆ PI-L32/15 surge separating inductor HAKEL spol. s r. o.
- ◆ DA-275 DFI protection with HF filter SALTEK s.r.o.
- ◆ RTO-xx surge separating inductor SALTEK s.r.o.

3 Communication

Various communication interfaces may be used for communication, depending on the control system type. **At one moment, each interface may use one communication protocol autonomously only** (apart from the interface Ethernet where you can use multiple communication protocols at the same time).

3.1 RS232

All control systems are equipped with the communication interface RS232 as standard. This interface is suitable for debugging purposes or for connecting a local device. It is also suitable for connection over 15 m of distance and within a single switchboard if possible. If the line goes outside the switchboard, the cables must not go along power conductors and must go outside of sources of industrial interference.

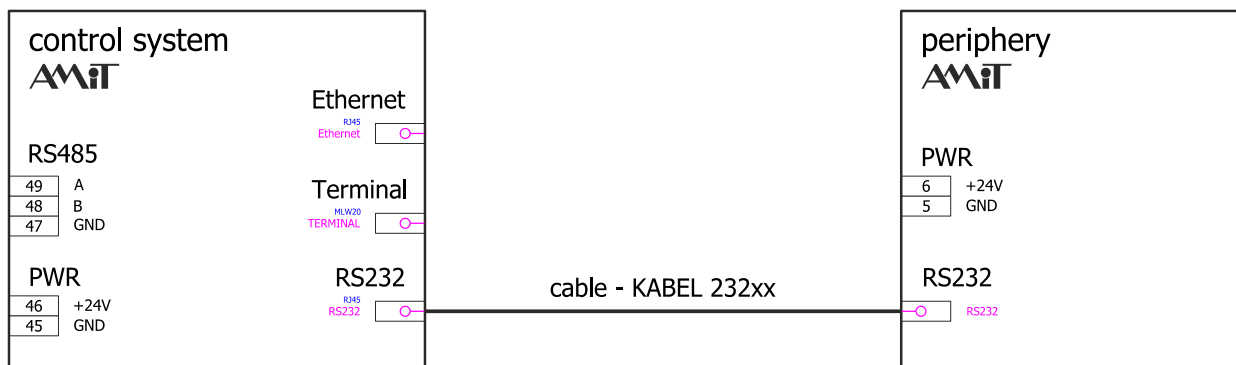

Fig. 5 – Connecting peripheral devices to the control system using RS232

We may use the line RS232 only for point-to-point communication; it cannot be used for power connection of more than two devices.

Descriptions of important PINs of the RS232 interface including types of cables for connecting control systems to peripheral devices is available in the application note “AP0027 – Connecting control systems and peripheral devices”, which is available for download free of charge at www.amitautomation.com.

Attention

Ground terminal of line RS232 on the control system is connected galvanically to the ground terminal of the power supply.

3.1.1 Connecting a PC to the control system

The line RS232 is most frequently used for service purposes. Using the line RS232, you can connect the PC with a service programme or a development environment. Depending on the connector of the RS232 interface of the control system, the connection can be made by cable

- ◆ **KABEL 232P** made by AMiT for control systems with connectors D-sub DE-9
- ◆ **KABEL 232RP** made by AMiT for control systems with connector RJ45

More information is available in the application note “AP0027 – Connecting control systems and peripheral devices”, which is available for download free of charge at www.amitautomation.com.

The cable connection diagram is available in their catalogue list. Catalogue lists for all AMiT products are available for download free of charge at www.amitautomation.com.

3.1.2 Connecting a serial terminal to the control system

In order to connect the serial terminal made by AMiT to a control system made by AMiT, signals are necessary.

- ◆ RxD data received
- ◆ TxD data transmitted
- ◆ GND line RS232 ground terminal

Signals CTS and RTS may or may not be connected, it does not influence the function.

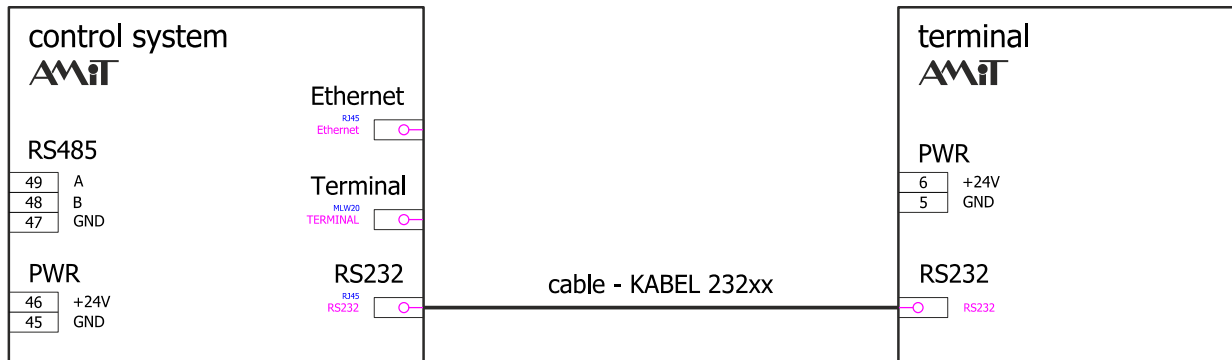

Fig. 6 – Connecting the terminal to the control system

Line RS232 can be used for making a connection with the terminal within the switchboard. The cable must go separately from power conductors and from industrial interference sources. Overvoltage protection for the line RS232 is not necessary within a single switchboard. Control systems can be connected to terminals made by AMiT by means of cables made by AMiT according to the following chart:

Control System Interface	Cable
WAGO	KABEL 232XZ
D-sub DE-9 (socket)	KABEL 232P *)
RJ45	KABEL 232RP **)

*) if you use **APT1000(G)** you may also use **KABEL 232XV**.

***) if you use **APT200** you may also use **KABEL 232RR(A)**.

More information is available in the application note “AP0027 – Connecting control systems and peripheral devices”, which is available for download free of charge at www.amitautomation.com.

The cable connection diagram is available in their catalogue list. Catalogue lists for all AMiT products are available for download free of charge at www.amitautomation.com.

3.1.3 Connecting a modem to the control system

The programme equipment of control systems allows the modem connection to provide communication between control systems. The connection can be made using a commuted telephone (an ordinary telephone line) line or a GSM/GPRS modem (mobile phone network). You may also use a radiomodem if it supports emulation of AT commands.

Usually, this connection serves to connect the control system and control room, or for remote data collection.

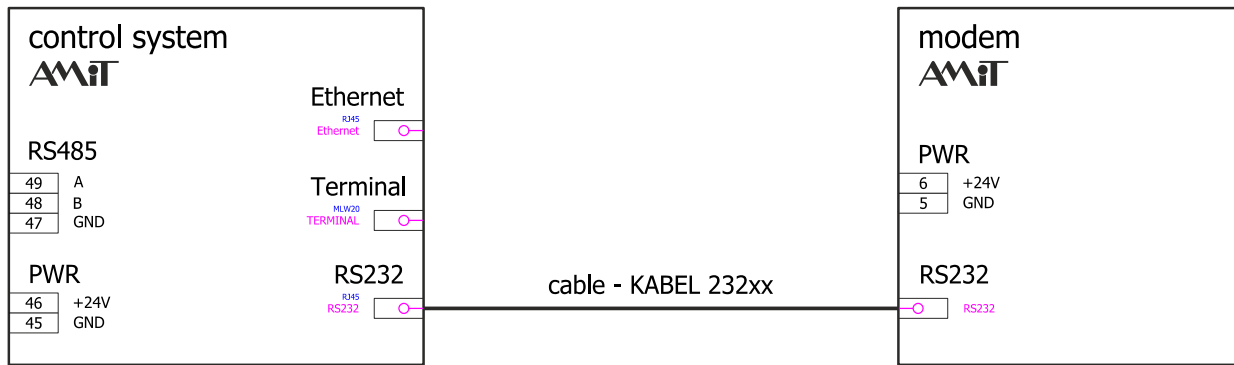

Fig. 7 – Connecting modem to the control system

Recommended types

- ◆ **DM-GSM** AMiT, spol. s r. o.
- ◆ **DM-GPRS** AMiT, spol. s r. o.

Attention

In order to communicate using GPRS, the modem **DM-GPRS** made by AMiT must be connected to the control system. No other modem can be used for communication by means of GPRS.

Control systems can be connected to modems made by AMiT by means of cables made by AMiT according to the following chart:

Control System Interface	Cable
D-sub DE-9 (socket)	KABEL 232RMS
D-sub DE-9 (plug)	KABEL 232RMP
RJ45	KABEL 232RR(A)

Control systems can be connected to general modems by means of cables made by AMiT according to the following chart:

Control System Interface	Cable
D-sub DE-9 (socket)	KABEL 232M9
D-sub DE-9 (plug)	KABEL 232P
RJ45	KABEL 232R9

More information is available in the application note “AP0027 – Connecting control systems and peripheral devices”, which is available for download free of charge at www.amitautomation.com.

Attention

You need to use a cable that has all modem signals connected to make the connection!

The cable connection diagram is available in their catalogue list. Catalogue lists for all AMiT products are available for download free of charge at www.amitautomation.com.

3.1.4 Connecting a communication converter to the control system

Apart from terminals and modems, it is also possible to connect other AMiT products to control systems in order to extend their communication options. These include e.g. converters from the line RS232 to the line RS485, converters from the line RS232 to Ethernet or web servers.

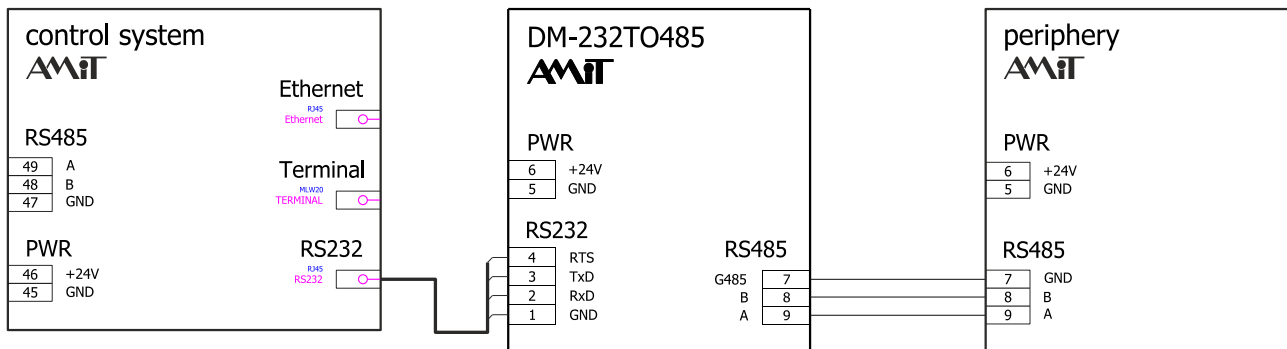

Fig. 8 – Connecting the converter DM-232TO485

Specific types of cables necessary to use when connecting such peripheral devices to the control systems are available in the application note “AP0027 – Connecting control systems and peripheral devices”, which is available for download free of charge at www.amitautomation.com.

The cable connection diagram is available in their catalogue list. Catalogue lists for all AMiT products are available for download free of charge at www.amitautomation.com.

3.2 RS485

All control systems made by AMiT are equipped or can be equipped with the line RS485 (by means of appropriate modules or converters). This line can be used for a point-to-point connection as well as for connecting multiple control systems including PC into a communication network, or to extend the control system by further peripheral devices (typically remote I/O made by AMiT with **ARION** protocol).

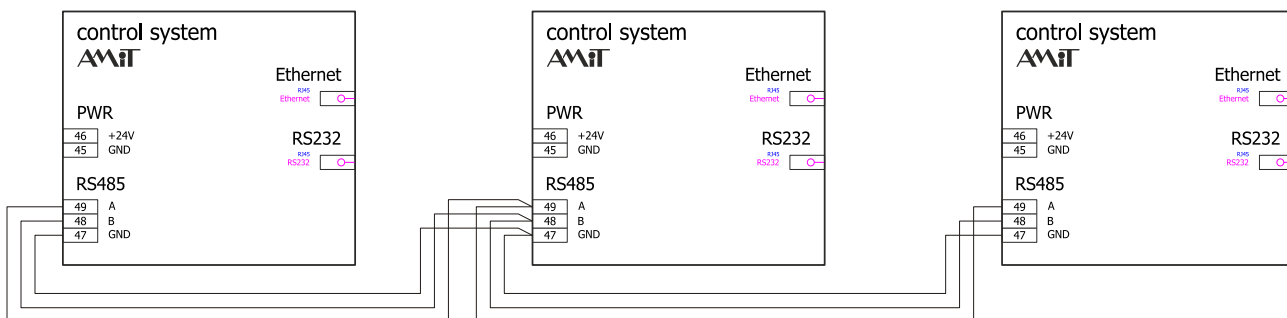

Fig. 9 – Connecting the line RS485

More information on connecting the line RS485 is available in the application note “AP0016 – Operating guidelines RS485” which is available for download free of charge at www.amitautomation.com.

3.3 CAN

Selected types of control systems made by AMiT are equipped or can be equipped with the line CAN (by means of appropriate modules). This line is suitable for making communication networks or for long-distance point-to-point communication in an industrial environment.

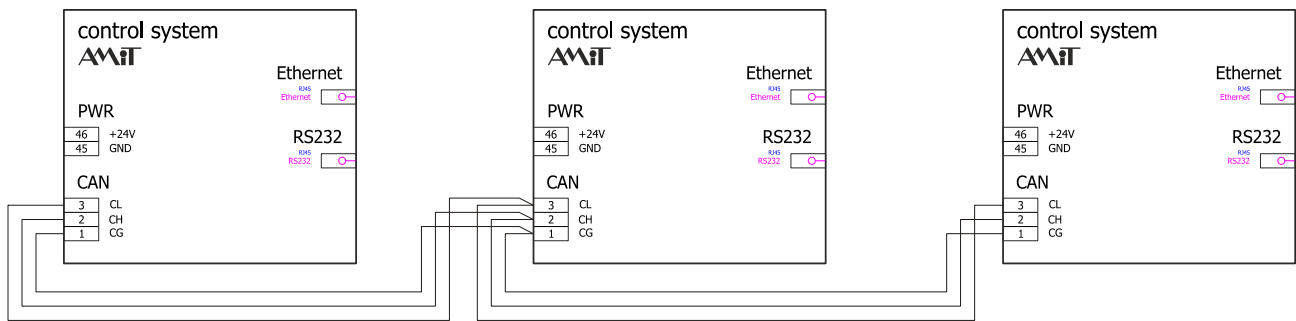

Fig. 10 – Connecting the CAN network

More information on connecting the CAN network is available in the application note “AP0029 – CAN network – Terms of Use” which is available for download free of charge at www.amitautomation.com.

3.4 M-Bus

Selected types of control systems made by AMiT can be equipped with the line M-Bus (by means of appropriate modules). This line is used e.g. for data collection from power supply meters.

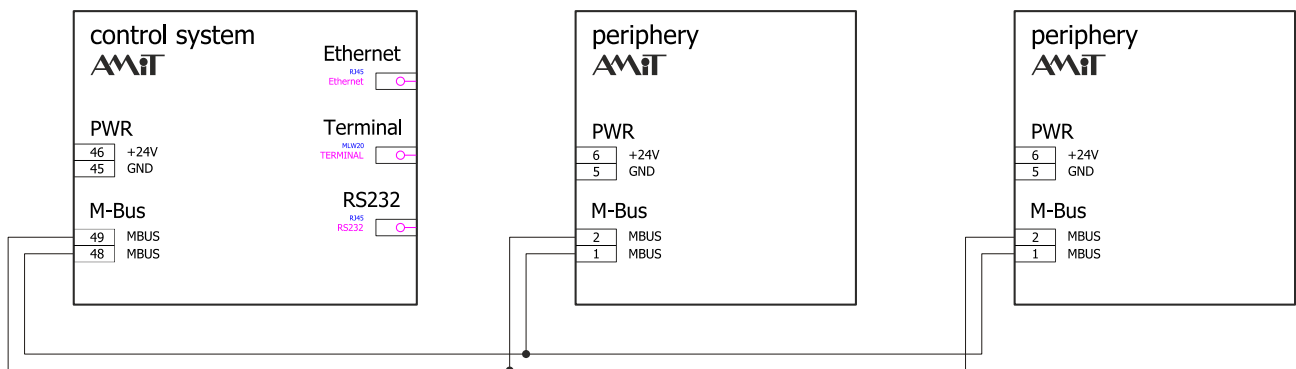

Fig. 11 – Connecting the M-Bus line

The issue of M-Bus line connection is covered in the standard CSN EN 13757-2.

Note:

In case it is not possible to fit the system with the M-Bus line, we can use e.g. line RS232<->M-Bus converter (not within AMiT production). Recommended and verified types of converters are available in application note “AP0010 – Communication in M-BUS network” which is available for download free of charge at www.amitautomation.com. This application note also includes a list of devices communicating by means of the M-Bus protocol that have been verified by AMiT technical support department.

3.5 Interface for a Parallel Terminal

This interface is included in systems such as **AMiRiS**, **AMAP** and **ADOS**. It is possible to connect the terminal **APT130** by means of a parallel interface to control systems of type **AMiRiS** and **AMAP**. The control system of **ADOS** type can be ordered including the terminal that is designed solely for this control system type.

Attention

*It is not possible to connect terminal **APT130** to a control system of type **ADOS**!*

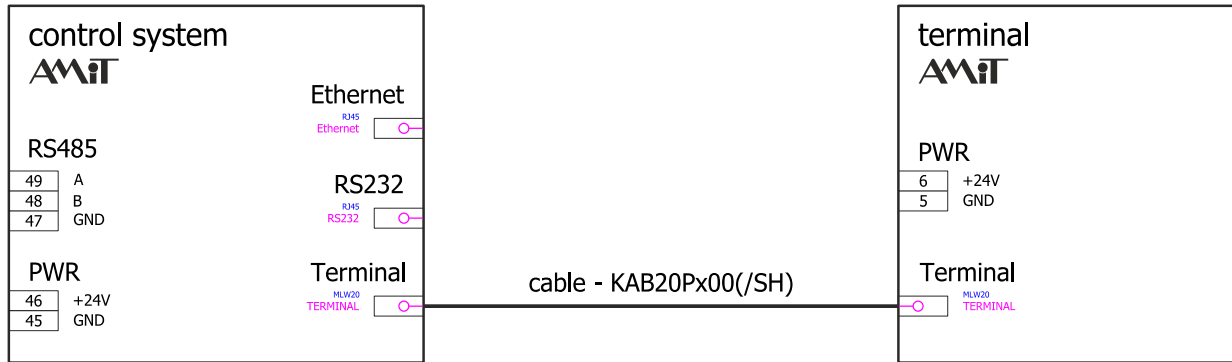

Fig. 12 – Connecting the terminal using a parallel interface

The parallel terminal can be connected to the control system only within the distance of 2 m from the control systems, and the connection must be carried out only within the switchboard the control system is installed in. The connecting cable must not run outside of the switchboard; it has to be laid separately from power conductors and from industrial interference sources.

The following cables produced by the company AMiT are suitable:

- ◆ **KAB20P100** (unshielded, length 100 cm)
- ◆ **KAB20P100/SH** (shielded, length 100 cm)
- ◆ **KAB20P200/SH** (shielded, length 200 cm)

More information is available in the application note “AP0027 – Connecting control systems and peripheral devices”, which is available for download free of charge at www.amitautomation.com.

Attention

The cable is an autonomous price-list item and is never included with a product!

3.6 Ethernet

All control systems made by AMiT are equipped or can be equipped with the Ethernet interface (by means of appropriate converters). According to the control system type, 10 Mbps or 100 Mbps Ethernet interface is used. The Ethernet interface is suitable for point-to-point connection as well as for connecting multiple control systems including PC into a communication network.

More information on Ethernet connection is available in the application note “AP0037 – Ethernet network – Terms of Use” which is available for download free of charge at www.amitautomation.com.

3.7 OpenTherm

All control systems can be equipped with the OpenTherm/Plus (OT/+) interface (by means of the **DM-OT** converter produced by AMiT). In order to allow communication with the control system, the **DM-OT** converter is equipped with interface RS485. The interface RS485 uses ARION protocol.

More information is available in the application note “AP0028 – OpenTherm device in ARION network”, which is available for download free of charge at www.amitautomation.com.

3.8 MP-Bus

All control systems can be equipped with the MP-Bus interface (by means of the **DM-MPBUS** converter produced by AMiT). In order to allow communication with the control system, the **DM-MPBUS** converter is equipped with interface RS485. The interface RS485 uses ARION protocol.

More information is available in the application note “AP0002 – Communication in MP-Bus network”, which is available for download free of charge at www.amitautomation.com.

3.9 Connecting Other Communication Interfaces

In case of request for the control system to communicate with peripheral devices by means of communication interfaces that are not usually available on control systems (not even when using AMiT-made converters), you may use various converters from other producers that are available on the market. A typical example is a request for the control system to communicate in LON network. In case of such request, you may proceed according to the application note “AP0019 – Communication in LON network”, which is available for download free of charge at www.amitautomation.com. A similar case is a request for communication in the network BACNet/IP, KNX/EIB or in a network using a different communication interface. In case of request for control system communication using these interfaces, you may again use communication interface converters (protocols).

4 Digital Inputs

All types of control systems manufactured are or may be equipped with digital inputs (using remote modules). The inputs are always separated galvanically from other control system circuits and are organized in sets of six, eight or sixteen with a single shared terminal. The octets are separated galvanically from each other.

Attention

Galvanic separation of individual octets must not serve for separation of safe and unsafe voltage!

Inputs of selected control systems are implemented as universal, i.e. they may be used both for AC signal and DC signal (see the corresponding technical documents), the manner of evaluation depends on the programme. The programme also allows application of digital inputs for measuring rotations or number of impulses as well. This matter is further described in the application note “AP0017 – Sensor inputs, measuring rotations and impulses”.

4.1 Digital inputs parameters

Digital input parameters are stated in user instructions for specific control systems, remote inputs or modules.

4.2 Connecting an active signal

Digital inputs are structured for two-conductor connection of the digital signal. We recommend powering active sensors from an autonomous power supply source. In smaller control systems, you may use the same power supply as for the control system.

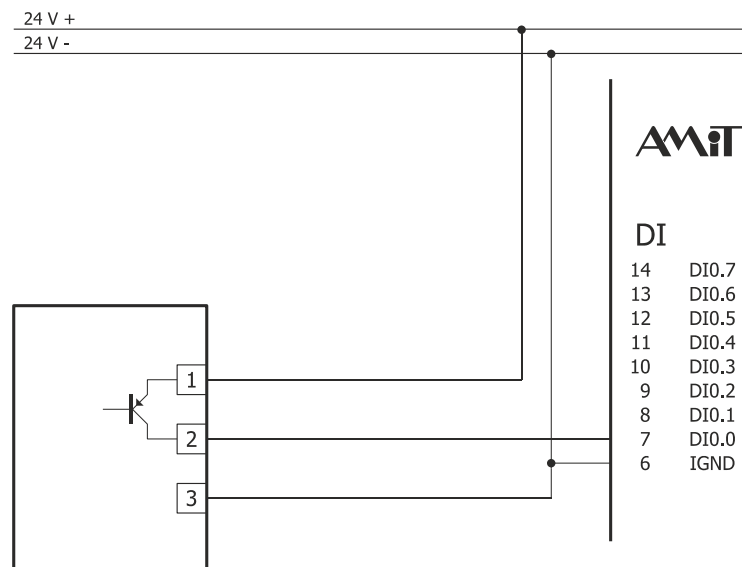

Fig. 13 – Connecting an active signal

4.3 Connecting a passive contact

Digital inputs are structured for two-conductor connection of the digital signal. We recommend powering digital inputs from an autonomous, galvanically separated, power supply source. In smaller applications, you may use the same power supply as for the control system. When using non-stabilized power supplies, make sure the minimum input voltage will not be lower (even in peaks) than the minimum voltage necessary for log. 1, otherwise proper functionality of digital inputs cannot be guaranteed.

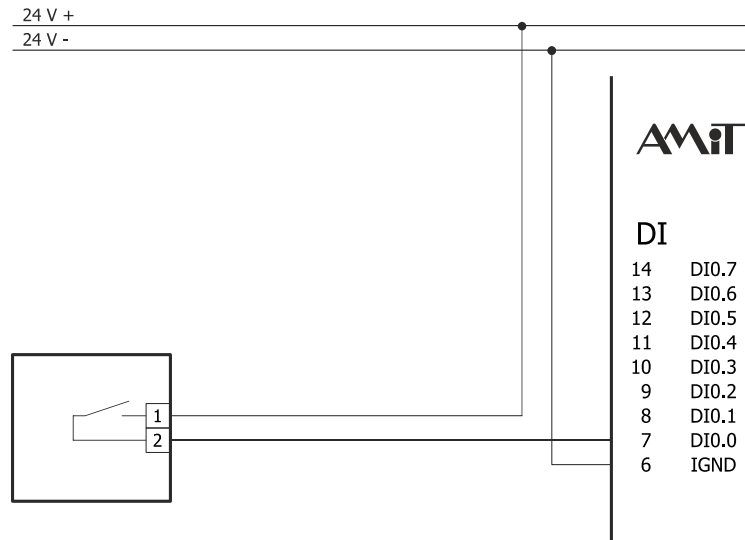

Fig. 14 – Connecting a passive contact

4.4 Connecting a dry contact

In selected control system types, digital inputs may be operated as dry contact. Digital inputs are structured for two-conductor connection of the digital signal.

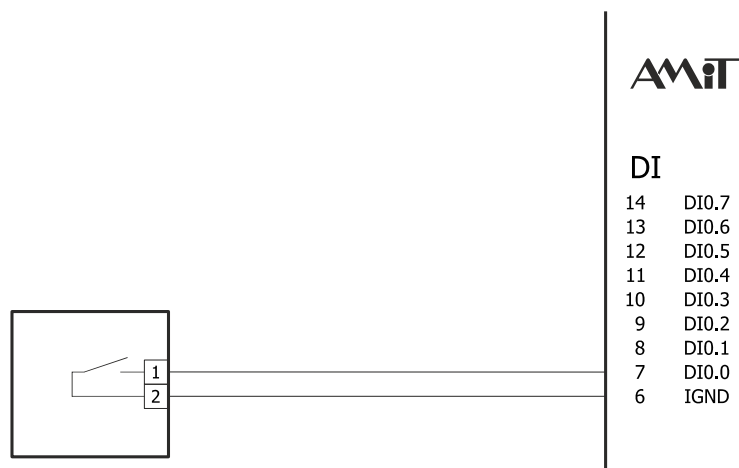

Fig. 15 – Connecting a dry contact

4.5 Connecting IRC sensors

IRC sensors can be connected to selected types of control systems. Maximum input frequency is determined by the characteristics of the digital input stated in the instructions for use of the selected control system. The issues of applicability of individual control systems for IRC sensor connection is covered in the application note “AP0017 – Sensor inputs, measuring rotations and impulses” which is available for download free of charge at www.amitautomation.com.

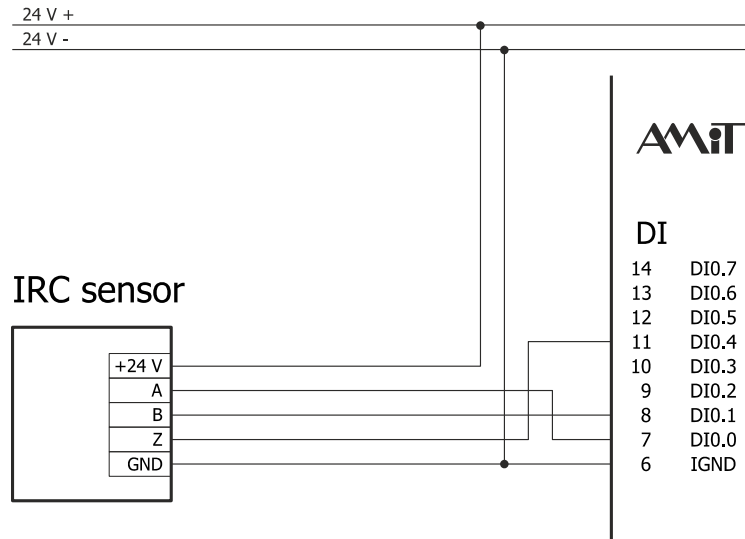

Fig. 16 – Connecting IRC sensors

4.6 Cabling

For environments with high level of interference, we recommend running digital input signals through a shielded cable. In common practice, an unshielded conductor is also suitable. Maximum distance for digital input connection is 200 m.

Digital inputs are best connected with cables with at least two cores of cross-section at least 0.5 mm².

When using shielded conductors, the shielding needs to be connected properly in the switchboard. If the shielding is connected incorrectly, the results may be even worse than with no shielding at all.

We recommend you connect the shielding as follows:

- ◆ Connect the shielding as near to the switchboard input as possible using a PE terminal.
- ◆ The connection must be made using a conductor as short as possible, with cross-section at least 2.5 mm².
- ◆ The shielding is not connected anywhere else in any point
- ◆ The switchboard internal cables go in unshielded conductor.

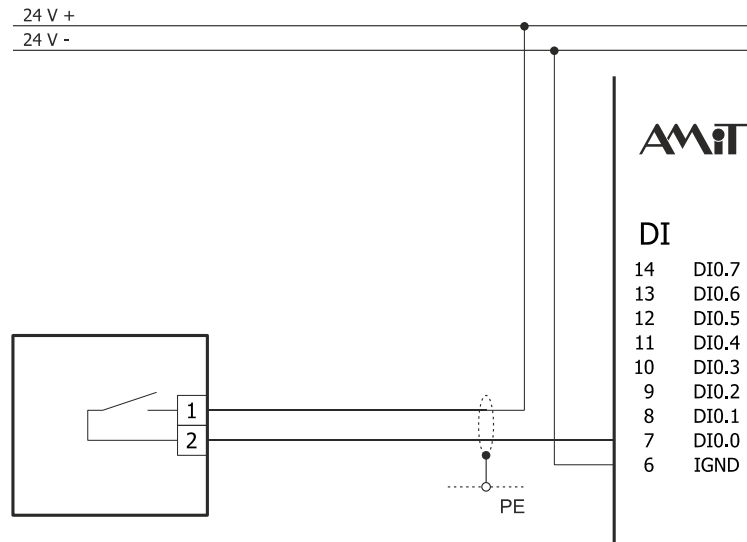

Fig. 17 – Shielding connection

4.7 Overvoltage protection

In order to provide trouble-free operation of digital inputs in an environment with risk of causing exceeded maximum voltage permitted on the control system input, it is necessary to use overvoltage protection for digital inputs.

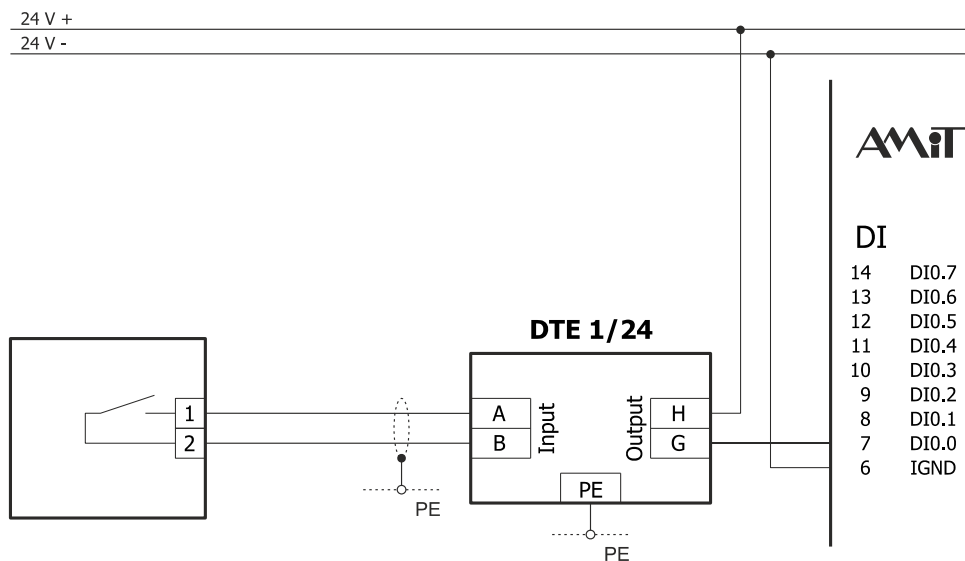

Fig. 18 – Connecting protection DTE 1/24 to protect a passive input

Recommended types

- ◆ DTE 1/24 HAKEL spol. s r. o.
- ◆ DTE 2/24 HAKEL spol. s r. o.
- ◆ DTNVE 1/24/0.5A HAKEL spol. s r. o.
- ◆ DM-024/1 R DJ SALTEK s.r.o.

5 Digital Outputs

All types of control systems manufactured are or may be equipped with digital outputs (using remote modules). They are implemented using relays, triacs or transistors (see documents on specific products). **When working on a design, we need to take into account whether resistive load (AC1) or inductive load (AC3) will be on the digital output. Parameters of digital outputs for the respective loads vary greatly!** In inductive loads AC3, a current several times higher than in stable conditions is created at the moment unplugging, which needs to be taken into account in the project.

5.1 Digital outputs parameters

Digital output parameters are stated in user instructions for specific control systems, remote outputs or modules.

5.2 Connecting digital active elements

5.2.1 Connecting relays, contactors

Outputs are connected through a two-conductor connection as simple switches. When switching inductive loads, interference suppression elements must be used, connected directly to terminals of elements switched (see Chapter “5.4 Suppressing Interference in Induction Elements”).

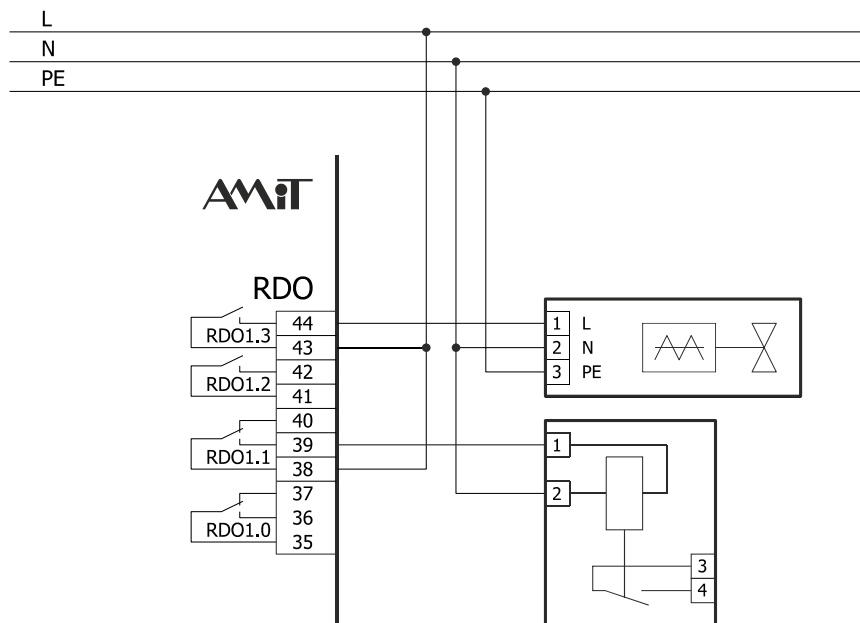

Fig. 19 – Connecting active elements on relay outputs

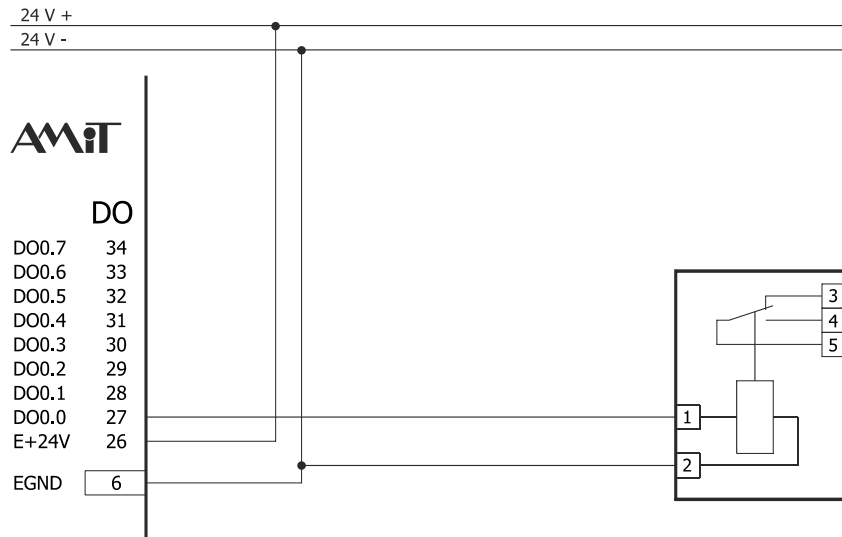

Fig. 20 – Connecting active elements on transistor output

5.2.2 Connecting an actuator (three-position control)

For three-position control, we use two relay or two transistor outputs. The outputs do not have internal protection. If the connection requires it, it is necessary to use external protection.

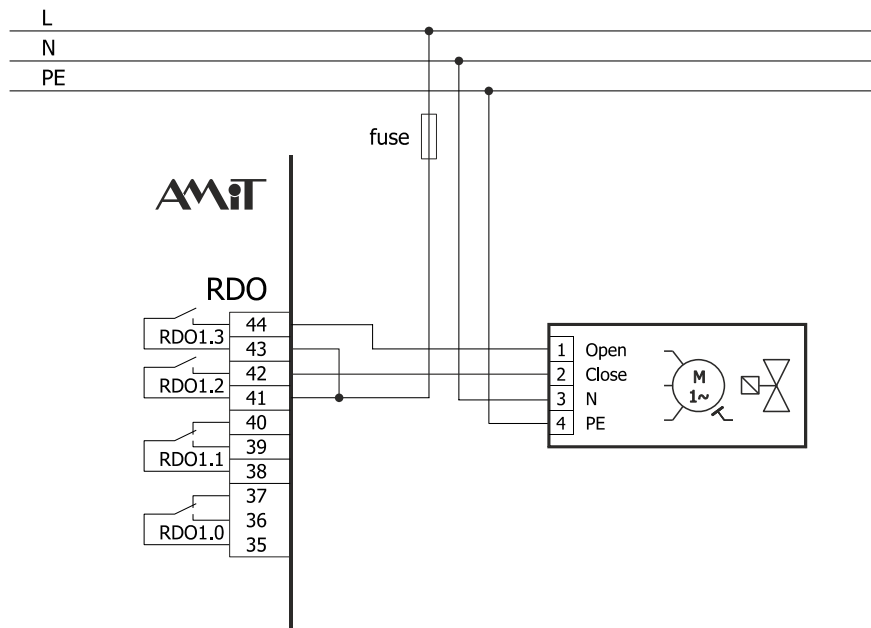

Fig. 21 – Connecting a three-position element

5.3 Cabling

To connect digital outputs, we need cables with at least two cores of cross-section at least 1 mm² (we select the conductor cross-section according to the current switched and connection length). The connection length depends on the signal type; we must take into account the influence of voltage drop on the cable. Typical maximum length is 200 m. When connecting elements that inherently cause interference (relays, contactors, valves), we must suppress the interference in these elements carefully.

5.4 Suppressing Interference in Induction Elements

If the control system is switched by an induction element (a relay, contactor, valve), we must make sure that the interference signals are suppressed as effectively as possible. We provide that by connecting a interference-suppressing element directly to the terminal of the element switched. The length of lead between the interference-suppressing element and the device switched must be as short as possible.

5.4.1 Suppressing interference using a varistor

Suppressing interference using a varistor is the most frequently used way of suppressing interference in an inductive element. The disadvantage of this method is the varistor ageing. The method is not very suitable in a low-quality network. However, it is suitable when using direct and alternating power supply both 24 V and 230 V. The switching voltage amount is selected according to the amount of the voltage switched. For 24 V, we use varistors 39 V; for 230 V, we use varistors 420 V. The varistor may already be a part of the inductive element provided directly by the manufacturer, or the switching element manufacturer may sell corresponding varistors in a special casing.

5.4.2 Suppressing interference using an RC member

Suppressing interference using an RC member is also a general way of suppressing interference in inductive load. It is suitable in low-quality networks as well. This method of suppressing interference is suitable for both direct and alternating power supply both 24 V and 230 V.

The amount of resistance and capacitor depends on voltage and currents. It is necessary to calculate optimal size of both elements for specific load values. The RC member may already be a part of the inductive element provided directly by the manufacturer, or the switching element manufacturer may sell corresponding RC members in a special casing.

5.4.3 Suppressing interference using a diode

This method may only be used for direct voltage. When using this method, we need to take into account the prolonged time for decoupling of switched relays by tens of milliseconds.

The diode may already be a part of the inductive element provided directly by the manufacturer, or the switching element manufacturer may sell corresponding diodes in a special casing.

5.5 Overvoltage protection

In order to provide trouble-free operation of digital outputs in an environment with risk of causing exceeded maximum voltage on the control system output, it is necessary to use overvoltage protection for digital outputs.

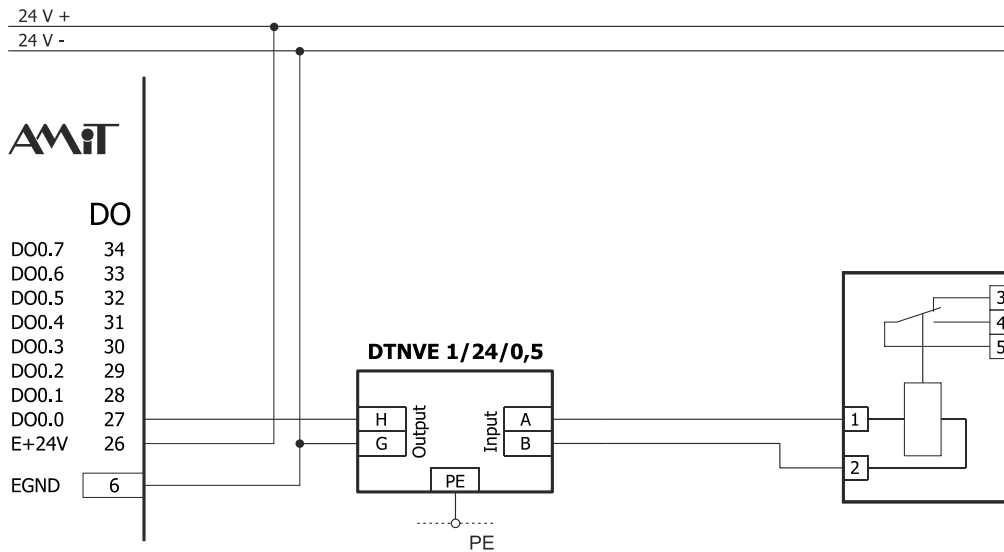

Fig. 22 – Output overvoltage protection

Recommended types

- ◆ DTNVE 1/24/0.5
 - ◆ DTNVE 1/24/5
 - ◆ DTNVE 2/24/5
 - ◆ DM-024/1 R DJ
- HAKEL spol. s r. o.
 HAKEL spol. s r. o.
 HAKEL spol. s r. o.
 SALTEK s.r.o.

6 Analogue Inputs

All types of control systems manufactured are or may be equipped with analogue inputs (using remote modules). Analogue inputs are usually connected galvanically with electronics of the control system and power supply (see the corresponding technical instructions). The number of analogue inputs depends on the control system type and configuration.

6.1 Analogue inputs parameters

Analogue input parameters are stated in user instructions for specific control systems, remote inputs or modules.

6.2 Connecting Analogue Detectors and Sensors

6.2.1 Connecting Passive Sensors

Resistance temperature sensor Ni1000 or Pt1000 can be connected directly to analogue inputs. When using the Ni1000 sensor, we get maximum precision of the converter by using the sensor with coefficient 6,180 ppm/°C. The sensor is connected through two conductors and it is suitable to make the connection with a shielded cable. Maximum cable length recommended is 100 m.

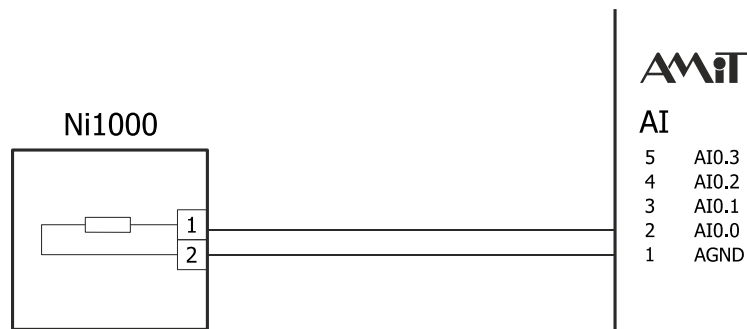

Fig. 23 – Connecting the Ni1000 sensor

More information on temperature range measured by means of analogue inputs is available in the application note “AP0015 – Measuring temperature and resistance” which is available for download free of charge at www.amitautomation.com.

6.2.2 Connecting a current sensor

With the input current range, the inputs are structured for two-conductor connection of the sensor 4 mA to 20 mA. The internal sensor resistance is 249 Ω.

Since the control system input is passive, the sensor has to be powered from an external power supply. To power analogue sensors, it is suitable to use an autonomous stabilized power supply or the same power supply as for the control system.

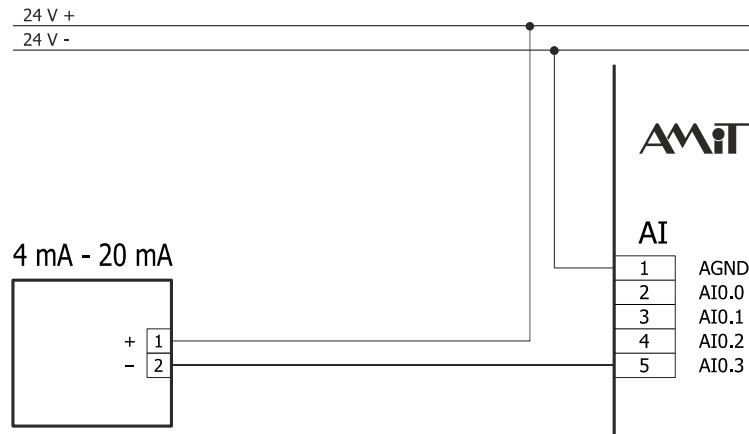

Fig. 24 – Connecting a current sensor

6.2.3 Connecting a voltage sensor

With the input voltage range, the inputs are structured for two-wire connection of the sensor 0 V to 5 V or 0 V to 10 V. Since the control system input is passive, the sensor has to be powered from an external power supply. To power analogue sensors, it is suitable to use an autonomous stabilized power supply or the same power supply as for the control system.

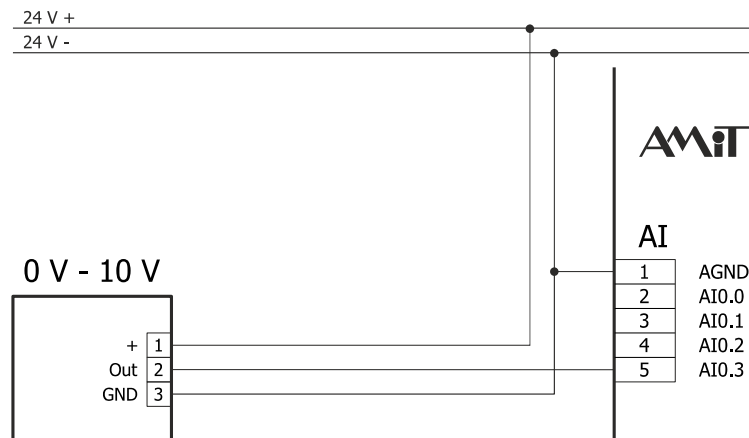

Fig. 25 – Connecting a voltage sensor

6.2.4 Alternative Uses of Analogue Inputs

If necessary, you may also use analogue inputs on selected devices for other purposes than to read the standard analogue signal 0 V to 5 (10) V, 4 mA to 20 mA or for connecting the resistance temperature sensor Ni1000 (Pt1000). Information on alternative uses of analogue inputs are available in the application note “AP0033 – Alternative use of analog inputs” which is available for download free of charge at www.amitautomation.com.

6.3 Cabling

In order to minimize the interference influence and provide trouble-free processing of analogue signals, it is necessary to connect these signals with shielded cables with at least two cores of cross-section at least 0.5 mm^2 . Connecting a shielding to the supply cables may influence the analogue value measured. There are three shielding-connection options:

- Shielding the cable from technology as well as shielding internal cabling is connected to PE terminal as close to the switchboard gate as possible. We do not connect the shielding anywhere else, not even on the control system protective terminal. The conductor leading from the terminal board to the PE terminal must have cross-section at least 2.5 mm^2 and it has to run as short as possible. This manner of shielding connection is the most frequent for connecting analogue inputs.

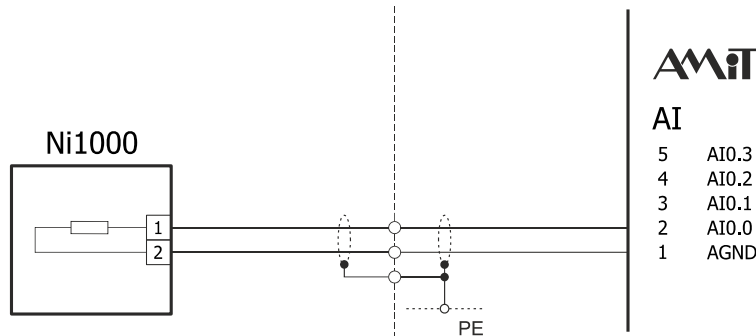

Fig. 26 – Connecting shielding to a PE terminal

- The shielding is connected only to analogue ground, on part of the control system. It is not connected anywhere else in any point. This method is suitable for connections of short cables.

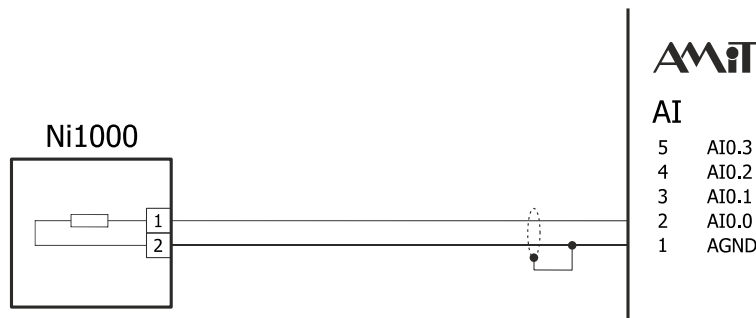

Fig. 27 – Connecting shielding to an AGND terminal

- Shielding of technology cables is connected to the PE terminal as close to the switchboard gate as possible. Shielding of internal cables is connected to the analogue ground of the control system.

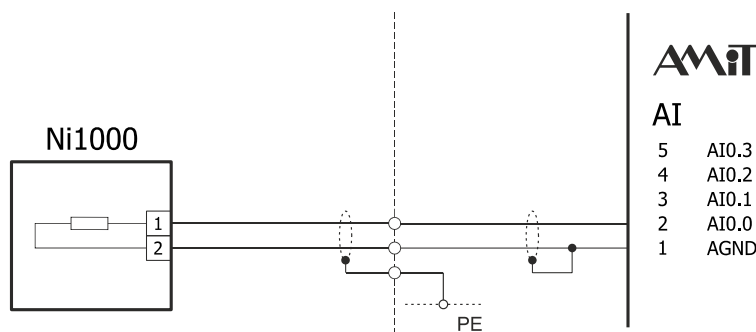

Fig. 28 – Combined shielding connection

6.4 Overvoltage protection

In order to increase the control system's endurance on part of analogue inputs, it is necessary to use overvoltage protection on each input with a risk of causing interference. Analogue input cables should not run parallel with power cables, lightning conductors and long metal objects. If this rule cannot be followed, it is necessary to use overvoltage protection before the control system. If a conductor runs like this from an active element, it is necessary to protect the sensor as well as the control system, since the sensor contains sensitive electronics, too.

Connecting protection to a current sensor

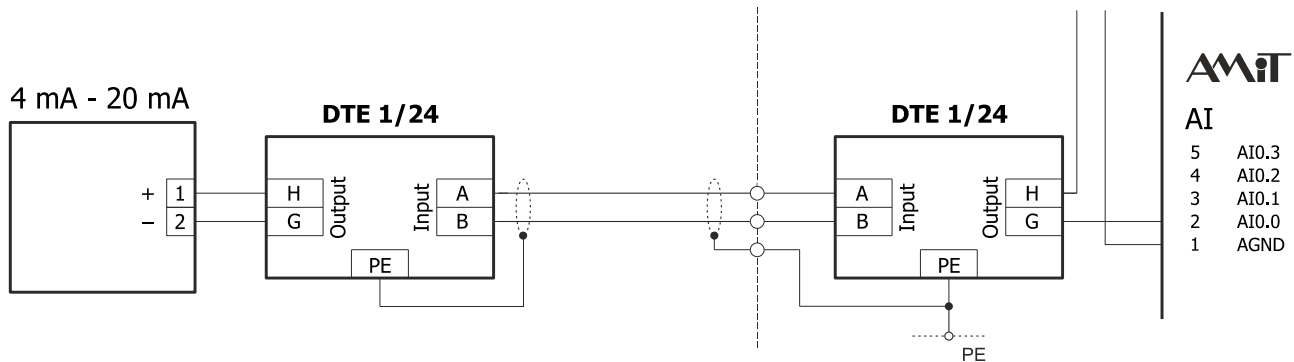

Fig. 29 – Example of connection of a protected current sensor.

Recommended types

- ◆ DTE 1/24 HAKEL spol. s r. o.
- ◆ DTE 2/24 HAKEL spol. s r. o.
- ◆ DTNVE 1/24/0,5A HAKEL spol. s r. o.
- ◆ DM-024/1 R DJ SALTEK s.r.o.

Connecting protection to a voltage sensor

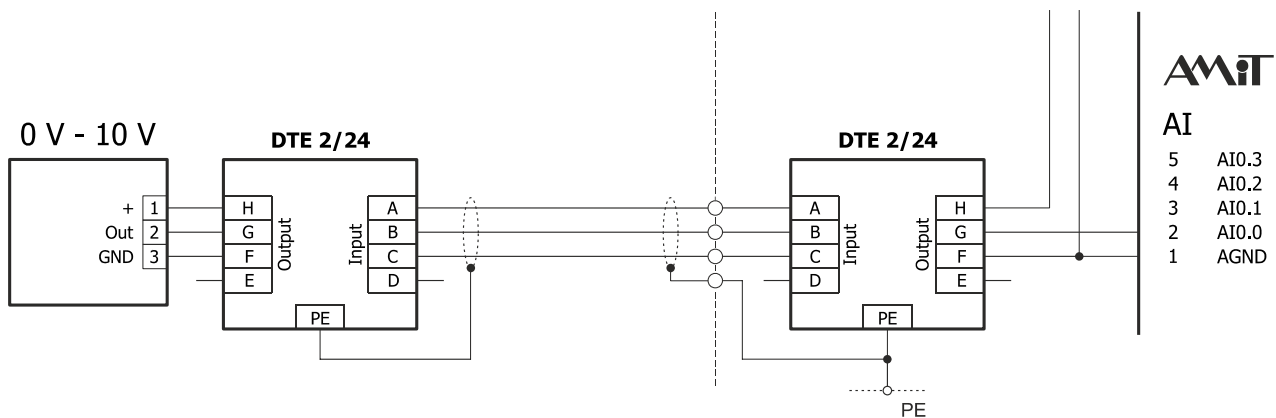

Fig. 30 – Example of connection of a protected voltage sensor

Recommended types

- ◆ DTE 2/24 HAKEL spol. s r. o.
- ◆ DTNVE 2/24/0.5 A HAKEL spol. s r. o.
- ◆ DM-024/2 R DJ SALTEK s.r.o.

7 Analogue Outputs

All types of control systems manufactured are or may be equipped with analogue outputs (using remote modules). Analogue outputs are usually connected galvanically with electronics of the control system and power supply (see the corresponding technical instructions).

7.1 Analogue output parameters

Analogue output parameters are stated in user instructions for specific control systems, remote outputs or modules.

7.2 Connecting analogue active elements

The analogue voltage output is structured for two-conductor connection of active elements. The shared terminal is AGND. The maximum consumption of the active element must not exceed 10 mA. The voltage output is galvanically connected with other control system circuit and with power supply terminals.

The active elements have to be powered from an autonomous power supply 24 V DC or 24 V AC.

7.3 Cabling

In order to make analogue active elements work well, it is necessary to conduct these signals through shielded conductors. As far as shielding connection is concerned, there are the same rules as with cabling in analogue inputs.

The analogue input cables must run separately from power conductors and away from strong interference sources.

Analogue input cables may run along with data cables. Maximum cable length for analogue output connection is 200 m.

Analogue signals are best conducted through a shielded cable with at least two cores, with cross.section at least 0.5 mm².

7.4 Overvoltage protection

In order to increase the control system's endurance on part of analogue outputs, it is necessary to use overvoltage protection on each input with a risk of causing interference. Analogue output cables should not run parallel with power cables, lightning conductors and long metal objects. If this rule cannot be followed, it is necessary to use overvoltage protection before the control system.

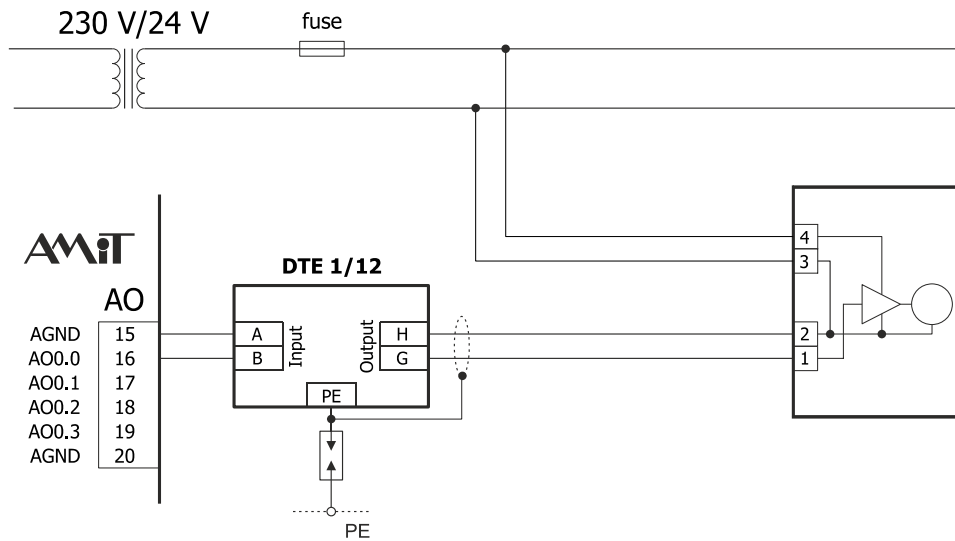

Fig. 31 – Example of overvoltage protection for an analogue output

Recommended types

- ◆ DTE 1/12
- ◆ DTE 2/12
- ◆ DM-012/1 R DJ

HAKEL spol. s r. o.
 HAKEL spol. s r. o.
 SALTEK s.r.o.

8 Connecting ground terminals

Depending on their type, control systems have galvanically separated or non-separated inputs/outputs. Information on galvanic separation of inputs/outputs is available in the operation instructions of the given control system.

Inputs/outputs not separated galvanically have a ground terminal galvanically connected to control system internal circuits and with the power supply ground. The line RS232 has a shared terminal galvanically connected to control system internal circuits and with the power supply ground.

8.1 Control system external circuits separated galvanically

In order to provide good endurance against interference, it is important to connect the PE terminal, switchboard ground and source GND in one point of the switchboard. When making this connection, we must make sure that all devices connected meet circuit requirements PELV.

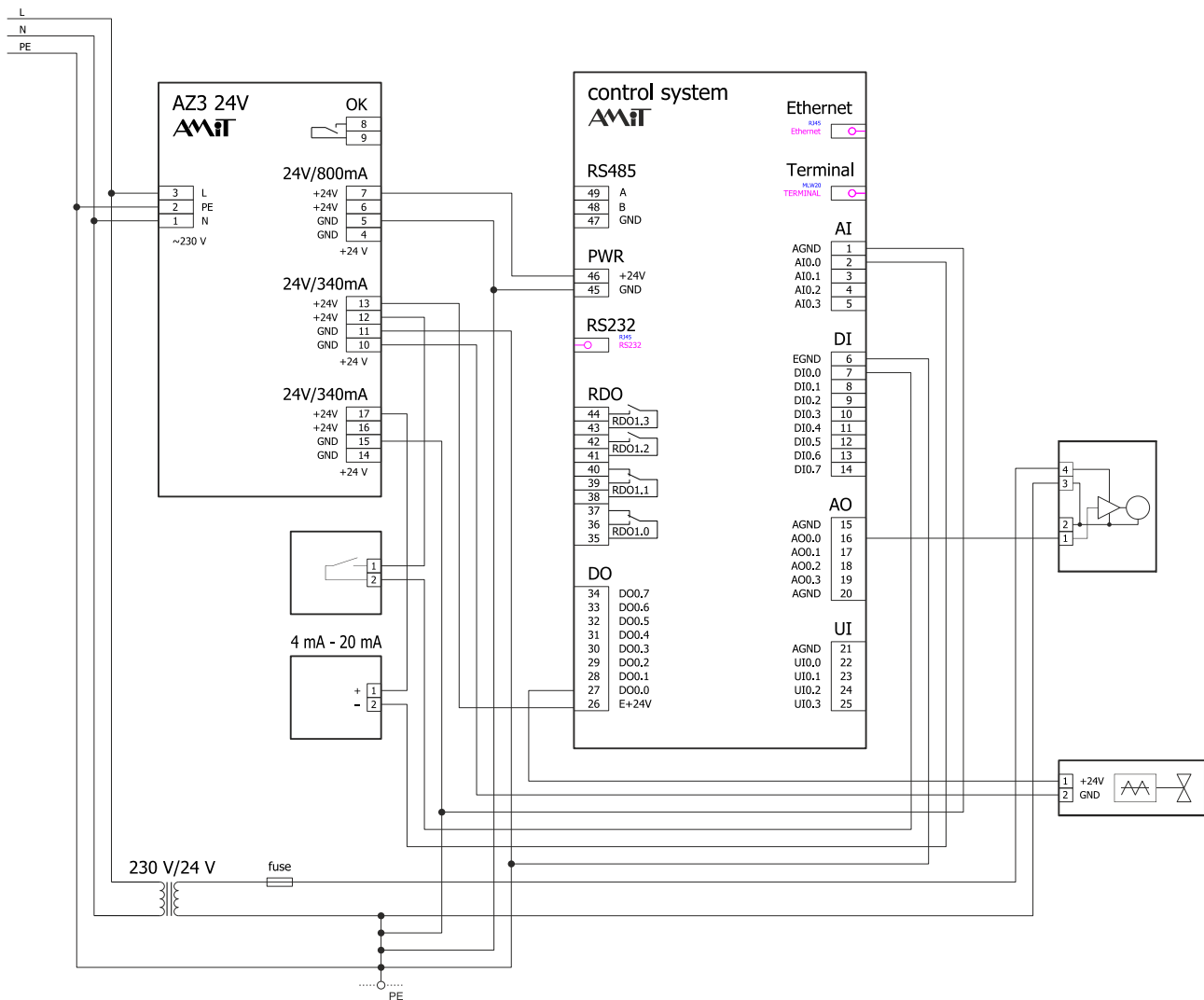

Fig. 32 – Example of system power supply from a multi-level source

8.2 Control system external circuits connected galvanically

Small applications may be powered from a single power supply source. When making this connection, we must make sure that all devices connected meet circuit requirements PELV.

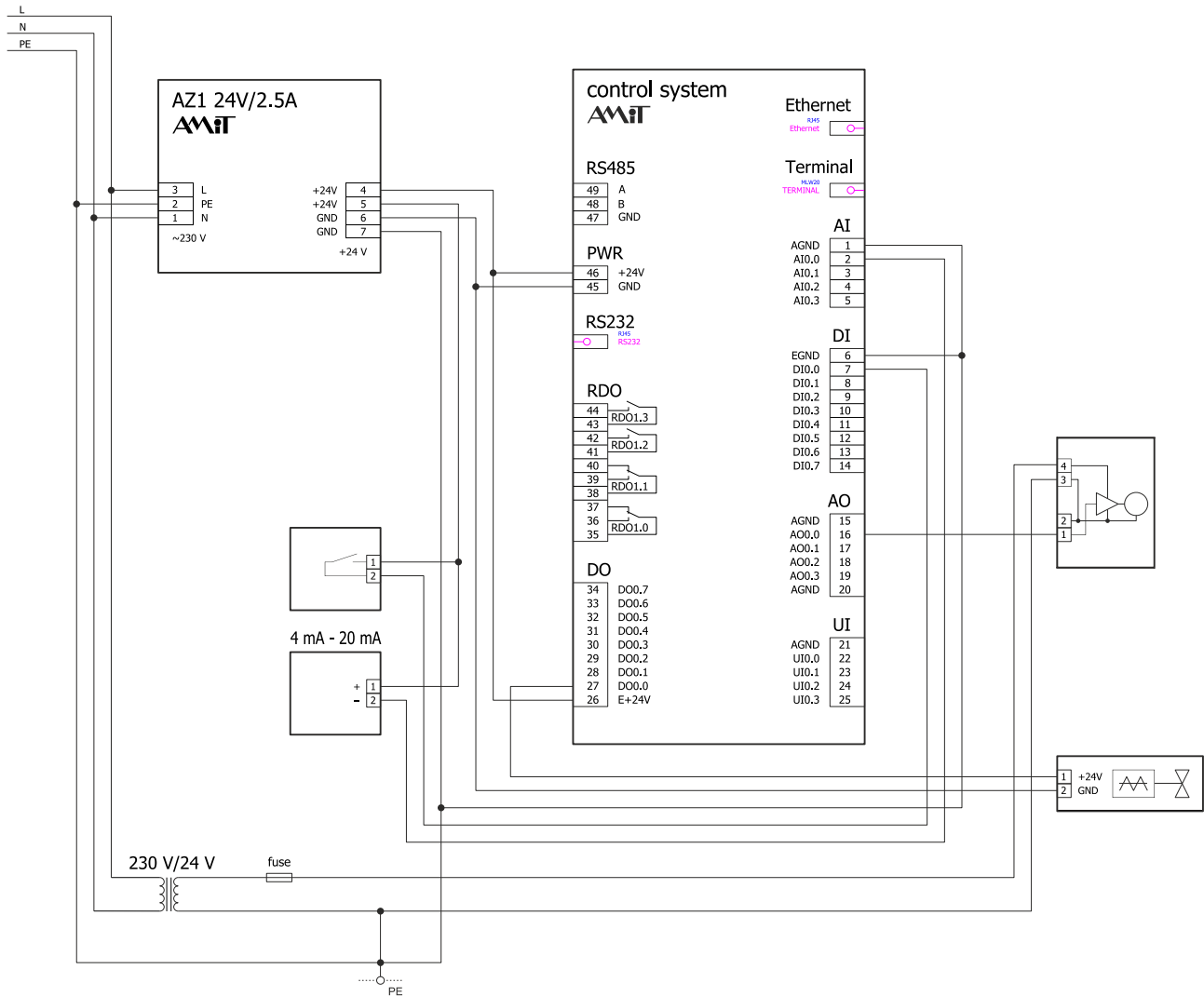

Fig. 33 – Example of system power supply from a single source

9 Extending Control Systems with Further I/O

If the number of inputs and outputs of a specific control system is insufficient for the given application, we may use remote input-output modules. To connect peripheral devices, you may therefore use the interface CAN (see application note “AP0007 – Communication in DIOCAN network” which is available for download free of charge at www.amitautomation.com) or the interface RS485 using the ARION communication protocol (see application note “AP0025 – Communication in ARION network – chart definition” which is available for download free of charge at www.amitautomation.com) or using the MODBUS protocol (see application note “AP0008 – Communication in MODBUS network” which is available for download free of charge at www.amitautomation.com).

10 Technical Support

All information on engineering the AMiT control systems will be provided by the technical support department of the company AMiT. Do not hesitate to contact the technical support via e-mail using the following address **support@amit.cz**.

11 Warning

The company AMiT, spol. s r. o. does not provide any guarantee concerning the contents of this publication and reserves the right to change the document with no obligation to inform any person or authority.

This document can be copied and redistributed under following conditions:

1. The whole text (all pages) must be copied without making any modifications.
2. All copies must include the AMiT, spol. s r. o. copyright and any other notices stated in the document.
3. This document must not be distributed for profit.

The names of products and companies used herein may be trademarks or registered trademarks of their respective owners.