

AMR-OP71RHP/xx

Programmable on-wall controller

- **Graphic black/white LCD**
- **Touch panel control**
- **RS485 communication interface and Poseidon®**
- **Measures temperature and ambient humidity**
- **Mounting on the wall**
- **Power supply, 24 V DC**

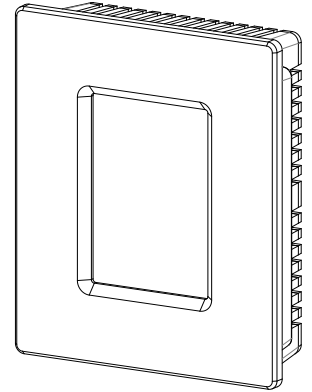

TECHNICAL DATA

Viewer	Graphic black/white LCD
Resolution	(64 × 132) pixels (non-symmetric point)
Display area	(58 × 38) mm
Backlight / lifetime	LED / min. 50,000 hours ¹⁾
Temperature, humidity measurement	Digital sensor
Measurement range temperature / humidity	-10 °C to 50 °C / 20 % to 80 %
Temperature measurement accuracy	±0.5 °C
Humidity measurement accuracy RH 20 % to 60 % RH 60 % to 80 %	±2.5 % ±{2.5 + [(RH-60)/10]} %
Stabilization time	45 min. ²⁾
RTC	CPU
RAM + RTC back-up	Replaceable lithium battery CR1632 ³⁾
Operation	Resistive touch panel
Communication	RS485, Poseidon
RS485 galvanic isolation	No
Number of units in a RS485 segment	256
Poseidon operation frequency	868 MHz
Poseidon range	TBD
Power supply	10 V DC to 30 V DC
Maximum consumption	30 mA at 24 V DC
Other	
Connection points	Terminal block CHF5/2
Ingress protection rate	IP20
Operating temperature range	-10 °C to 50 °C
Maximum ambient humidity	< 95 % non-condensing
Mounting	On-wall
Weight	0.12 kg
Dimensions (w × h × d)	(90 × 110 × 29) mm
Programming	DetStudio / EsiDet

¹⁾ Backlight drop to 50 %.

²⁾ At this time, accuracy is reduced to ±1 °C.

³⁾ Battery is not included in the delivery

ORDERING INFORMATION

AMR-OP71RHP/xx	On-wall controller
----------------	--------------------

	Box colour	Cover colour
AMR-OP71RHP/01	Black	Platinum

Note: Small recesses on the surface and colour inhomogeneity do not justify a warranty claim.

RECOMMENDED DRAWING SYMBOL

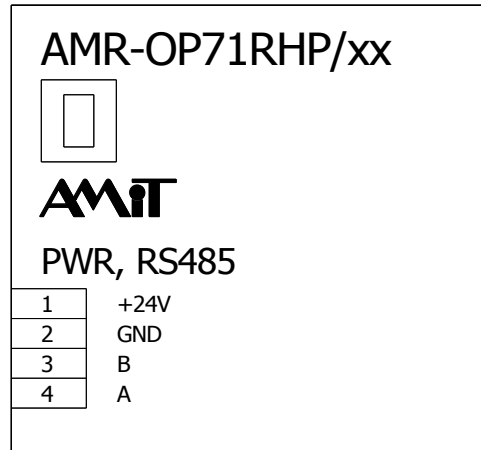

MECHANICAL DIMENSIONS

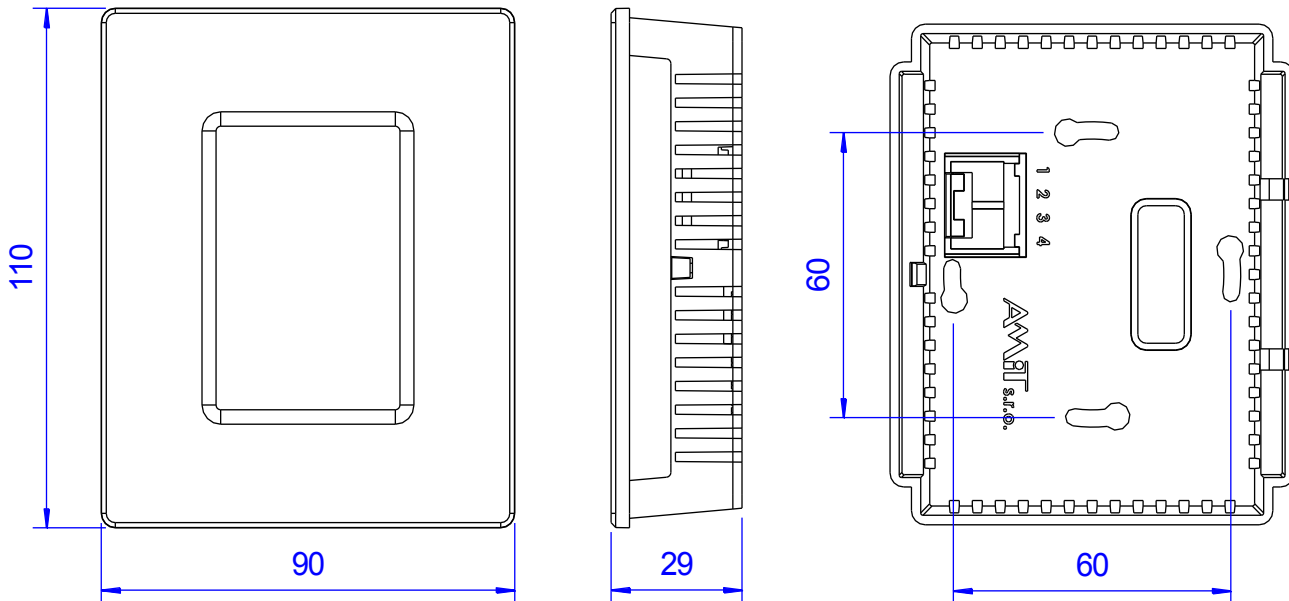

AMR-OP71RHP/xx

Programmable on-wall controller

POWER SUPPLY AND COMMUNICATION

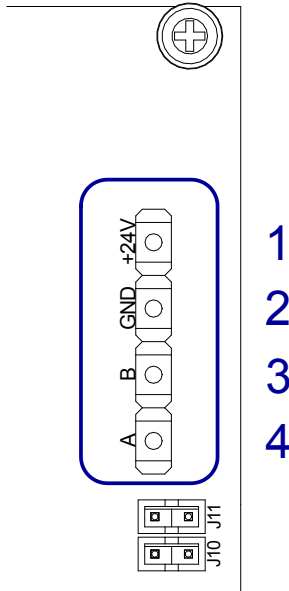

There is a single connector on the unit serving both for power supply and communication. The connector wiring is stated in the table below.

Terminal	Description
1	Power supply, +24 V DC
2	Common ground
3	RS485, signal B
4	RS485, signal A

RS485 CONFIGURATION JUMPERS

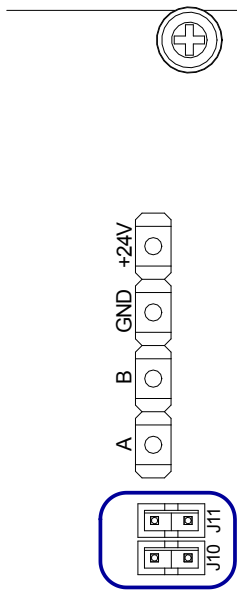

Each unit on RS485 communication line must have terminating resistance set correctly. We set the termination by means of configuration jumpers located under the cover of the unit next to the connector for RS485. If the jumpers are in place, the termination is connected. Terminal stations must have always connected RS485 termination, intermediate stations – disconnected.

Jumpers	Description
Fitted	Terminal station – termination active
Not fitted	Intermediate station – termination inactive

Data in this datasheet is informative only. Binding detailed information can be found in the operation manual ([amr-op71rhp_x_d_en_100.pdf](#)). Documentation can be downloaded from www.amitautomation.com.