

DMM-AO8I

Module of analogue outputs with protocol MODBUS

- **Module of 8 current analogue outputs**
- **Outputs without galvanic isolation**
- **Operation through RS485 interface, protocol MODBUS RTU**

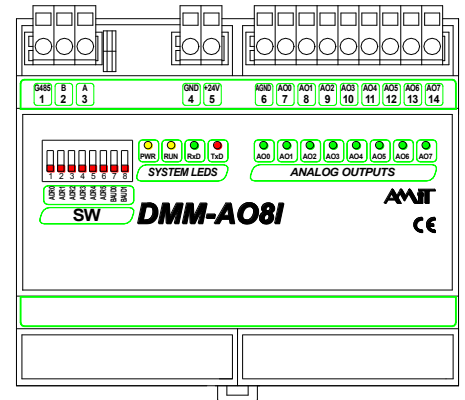

TECHNICAL DATA

Outputs	8
Output current	0 mA to 20 mA DC
Maximum load impedance	500 Ω
Converter resolution	12 bits
Setting accuracy	±1 LSB
Absolute setting error	< 1 %
Common wire	Analogue ground
Galvanic isolation of outputs	No
Communication	RS485
Interface galvanic isolation	Yes *)
Overvoltage interface protection	Transil 600 W
Communication speeds	9600 bps to 57600 bps
Number of modules on RS485 network	63
Number of modules on RS485 segment	31
Power supply	19.2 V DC to 28.8 V DC
Power consumption (without outputs)	Max. 150 mA at 24 V DC
Others	
Connection	Cage clamps WAGO 231
Ingress protection rate	IP20
Operating temperature range	0 °C to 50 °C
Maximum ambient humidity	< 95 % non-condensing
Mounting	DIN rail 35 mm
Weight	250 g
Dimensions (w × h × d)	(106 × 97 × 73) mm

The terminal AGND is internally connected with terminal GND of power supply connector.

*) Insulation strength 500 V AC/1 minute, galvanic isolation must not be used for safe and unsafe parts separation.

ORDERING INFORMATION

DMM-AO8I	Module of 8 analogue current outputs with protocol MODBUS, connectors WAGO
-----------------	--

TERMINALS IDENTIFICATION

Terminal	Signal	Description
1	G485	RS485, shielding
2	B	RS485, wire B
3	A	RS485, wire A
4	GND	Power supply, ground
5	+24V	Power supply +24 V DC
6	AGND	Analogue GND
7	AO0	Output 0

Terminal	Signal	Description
8	AO1	Output 1
9	AO2	Output 2
10	AO3	Output 3
11	AO4	Output 4
12	AO5	Output 5
13	AO6	Output 6
14	AO7	Output 7

TERMINALS LOCATION

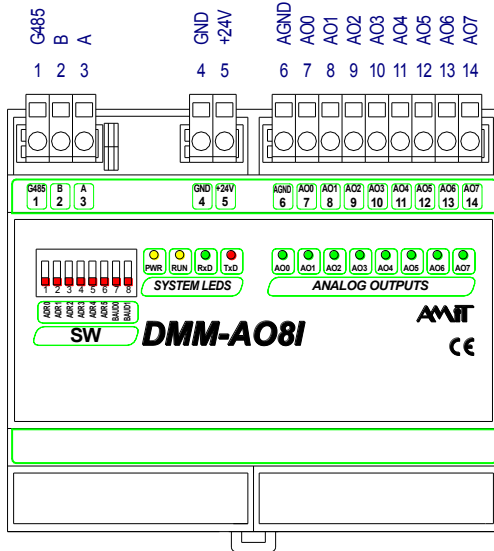

RECOMMENDED DRAWING SYMBOL

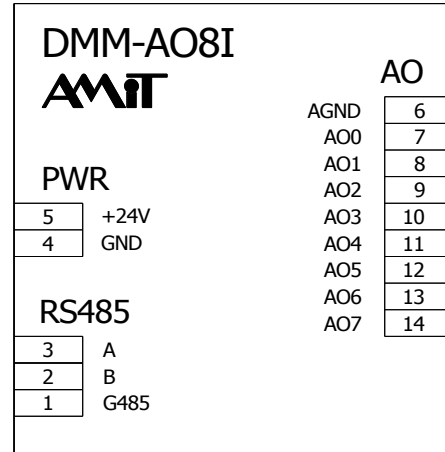

MECHANICAL DIMENSIONS

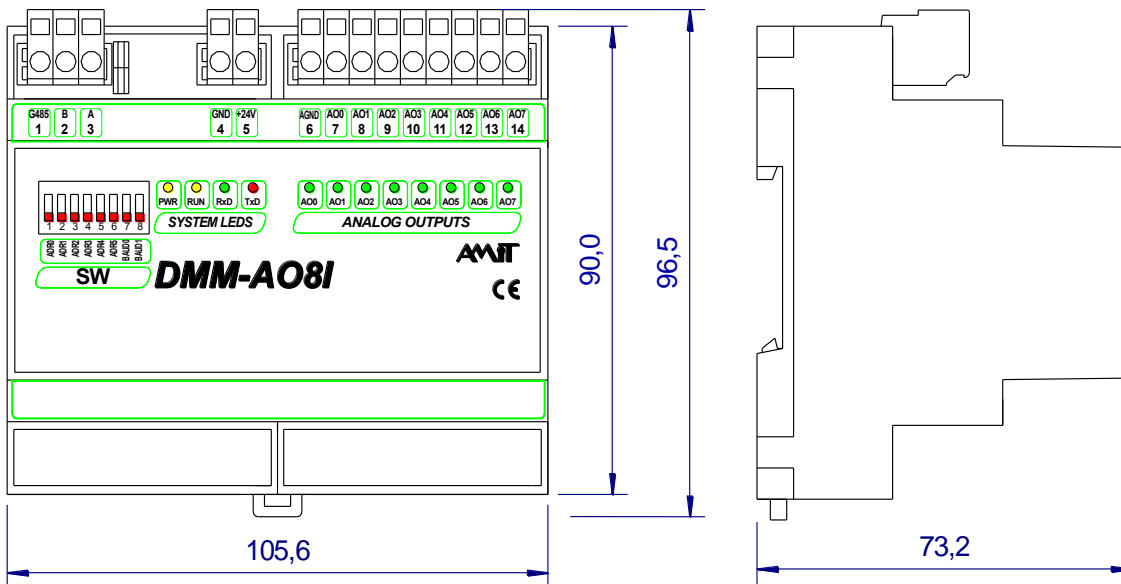

JUMPERS – RS485 INTERFACE

J6, 1-2	Idle state line definition + A termination
J6, 3-4	Idle state line definition + B termination

DMM-AO8I

Module of analogue outputs with protocol MODBUS

PARITY SETTINGS

Turn the unit power supply off, set all switches to OFF position and turn the power supply on again. The parity can be set by the switches ADR0 (DIP 1) and ADR1 (DIP 2) according to a table:

ADR0 (DIP 1)	ADR1 (DIP 2)	Parity
OFF	OFF	None
ON	OFF	Even
OFF	ON	Odd

The settings must be confirmed by switching the switch BAUD1 (DIP 8) to a position ON ("light snake" is running on module LEDs). Parity settings are displayed on corresponding LEDs. The change of switches settings will be active after turning the module off and on again.

SETTINGS OF ADDRESS AND COMMUNICATION SPEED

Address settings can be performed by the switches ADR0 (DIP 1) to ADR5 (DIP 6). Available address values are 1 to 63. **Address 0 is not allowed!** Communication speed settings can be performed by the switches BAUD0 (DIP 7) and BAUD1 (DIP 8).

ADDRESS

DIP	Value
ADR0 (DIP 1)	Value of 1
ADR1 (DIP 2)	Value of 2
ADR2 (DIP 3)	Value of 4
ADR3 (DIP 4)	Value of 8
ADR4 (DIP 5)	Value of 16
ADR5 (DIP 6)	Value of 32

COMMUNICATION SPEED

BAUD0 (DIP 7)	BAUD1 (DIP 8)	Communication speed
OFF	OFF	9600 bps
ON	OFF	19200 bps
OFF	ON	38400 bps
ON	ON	57600 bps

An example of address: address = 35, the switches 1, 2 and 6 (1 + 2 + 32) are ON. The change of switches settings will be active after turning the module off and on again.

SUPPORTED MODBUS FUNCTIONS

Function	Use
3	Reading of outputs values
6	Writing to one output
16	Writing of multiple outputs

The values of individual outputs (written to A/D converters) are mapped to the network Modbus by the holding registers according to the table.

DMM-AO8I output	Modbus HR number	Modbus HR type	Description
AO0	0	R/W	Value written to A/D converter of output AO0
AO1	1	R/W	Value written to A/D converter of output AO1
...
AO6	6	R/W	Value written to A/D converter of output AO6
AO7	7	R/W	Value written to A/D converter of output AO7

The values are written in a range 0 to 32767 into the registers. This corresponds to a range 0 % to 100 % of analogue output. If the output should be set to 2 mA, a value 3279 must be written by Modbus.

Warning: A unit has implemented SW **WATCHDOG**. If the unit does not receive (for 10 seconds) any valid frame (even for another unit on the network), all outputs are set 0 mA.

Other documentation and examples can be downloaded from www-amitautomation.com.