

AMiNi5D

Compact control system with display

- 8× GI digital output 24 V / 0.3 A DC
- 8× GI digital input 24 V DC / AC
- 8× analogue input (12-bit)
U/I/Ni1000/Pt1000/NTC
- 4× analogue output (12-bit) 0 V to 10 V
- RS232, RS485 GI, Ethernet 10/100 Mbps
- Web server
- Micro SD card slot
- Mounted on a 35 mm DIN rail
- LCD display (320 × 240) pixels, keyboard

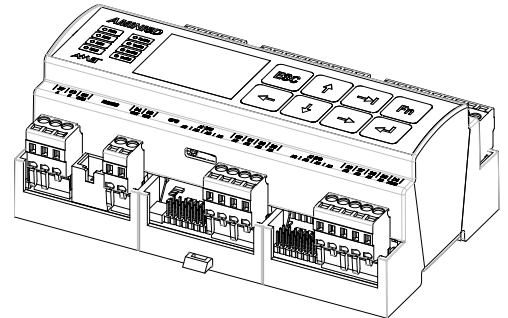

TECHNICAL DATA

CPU	STM32F437
FLASH memory	2 MB + 16 MB
RAM memory	1 MB + 16 MB
SRAM + RTC back-up	10 years
Memory card slot	Micro SD
Inputs	8× DI + 8× AI
Digital inputs	24 V DC/AC
Analogue inputs	0 V to 10 V/0 mA to 20 mA/ Ni1000/Pt1000/NTC 10 kΩ/NTC 20 kΩ
Galvanically isolated digital inputs	Yes *)
Galvanically isolated analogue inputs	No
Outputs	8× DO + 4× AO
Digital outputs	24 V / 0.3 A DC
Analogue outputs	0 V to 10 V (max. 10 mA)
Galvanically isolated digital outputs	Yes *)
Galvanically isolated analogue outputs	No
Communication	
Serial communication channels	1× RS232 (RJ45), according to EIA-561 1× RS485 (WAGO connectors)
Ethernet	10/100 Mbps, RJ45, according to IEEE802.3
Galvanically isolated RS232	No
Galvanically isolated RS485	Yes *)
Power supply	19.2 V DC to 28.8 V DC
Power consumption (w/o outputs)	Max. 120 mA at 24 V DC
Other	
Display	TFT IPS, (320 × 240) pixels
Keyboard	8 buttons
Signals connection	WAGO 231 clamp connectors
Ingress protection rate	IP20
Operating temperature range	-20 °C to +70 °C
Maximum ambient humidity	< 95 % non-condensing
Mounting	On a 35 mm DIN rail
Weight	0.36 kg
Dimensions (w × h × d)	(160 × 100 × 62) mm

*) Isolation strength 300 V AC / 1 min., galvanic isolation must not be used for separation of dangerous parts.

ORDERING INFORMATION

AMiNi5D	Control system, WAGO connectors
----------------	---------------------------------

TERMINALS IDENTIFICATION

Analogue outputs	AO	4× 12-bit analogue output without GI	1 to 5
Digital inputs	DI	8× galvanically isolated input	6 to 14
Digital outputs	DO	8× galvanically isolated output	15 to 23
Analogue inputs	AI	8× 12-bit analogue input without GI	24 to 32
Power supply	PWR	power supply 24 V DC	33 to 34
Communication	RS485		35 to 37

LOCATIONS OF TERMINALS

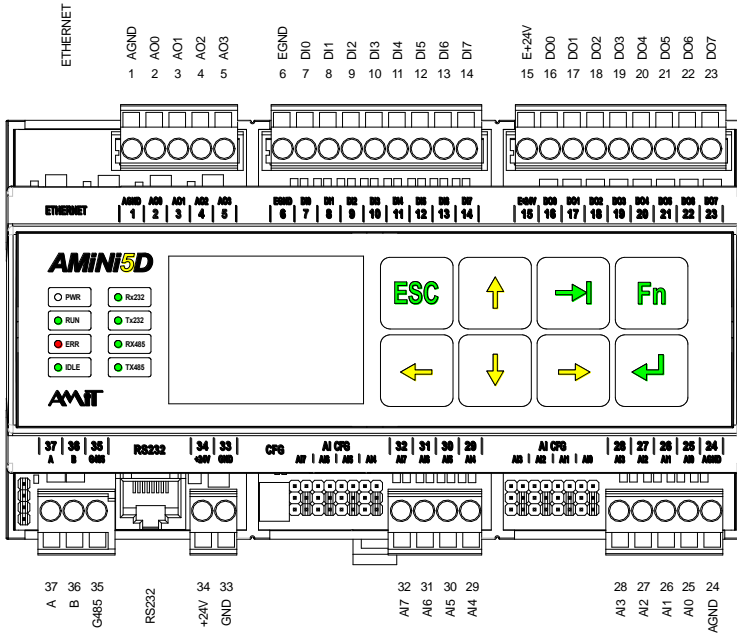

RECOMMENDED DRAWING SYMBOL

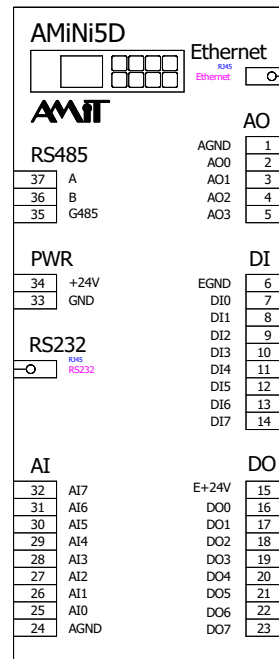

Note: Terminals GND, AGND and RS232 – GND are internally connected.

MECHANICAL DIMENSIONS

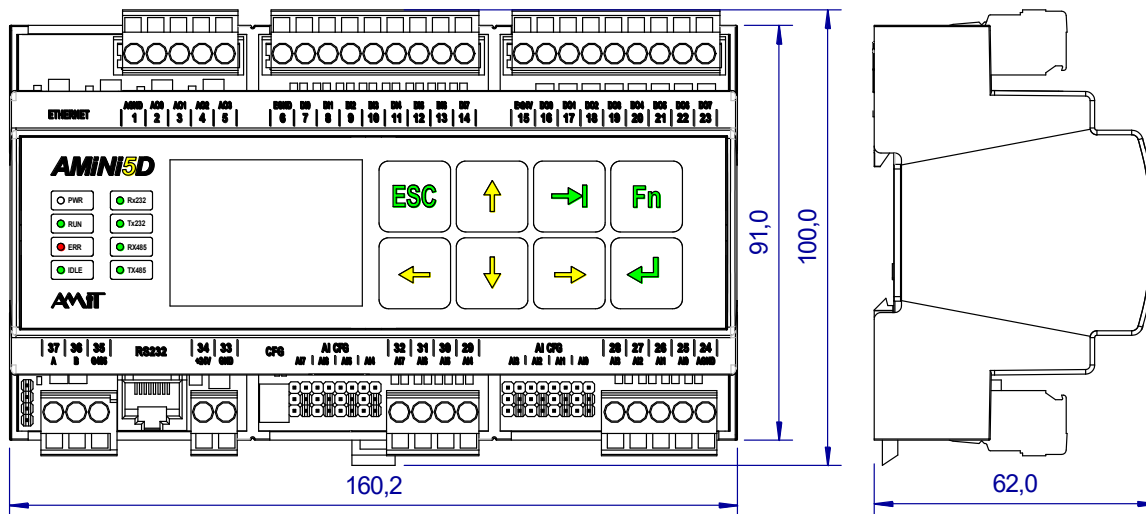

Data in this datasheet is informative only. Binding detailed information can be found in the operation manual ([amini5d_g_en_xxx.pdf](#)). Documentation can be downloaded at [amitautomation.com](#).

The manner of usage of the system peripherals is determined by the current options of DetStudio (Gen2 E+) development environment.